

REV.	DESCRIPTION	DRAWN	CHECKED	APPROVED
A	NEW RELEASE	DMJ 07/18/07'	~	LJC 07/17/07'
B	更改料号代码	YCH 08/04/07'	~	
C	Change The Dimension	YCH 11/25/09'	~	LJC 11/25/09'

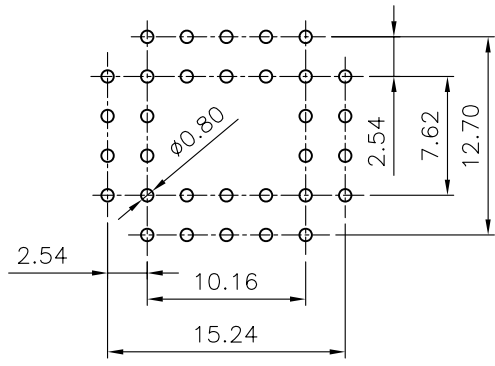
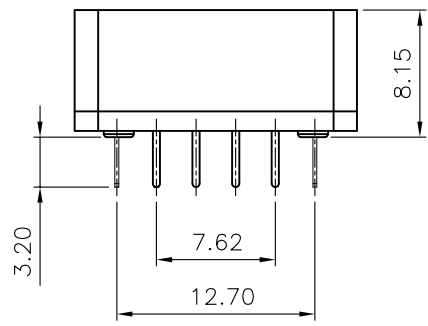
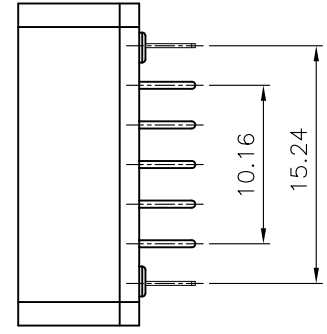
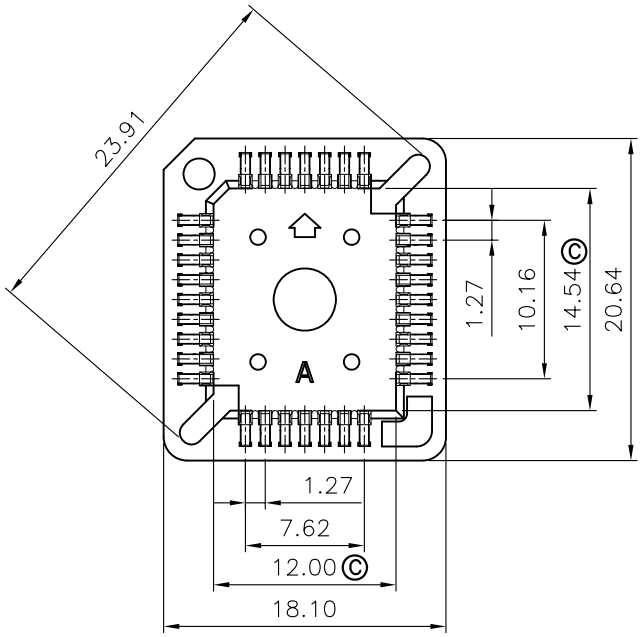

RECOMMEND PCB(V/T TYPE) LAYOUT
TOLERANCE=±0.05

NOTES:

- MATERIAL
 - INSULATOR:THERMOPLASTIC(UL 94V-0).
 - CONTACT: COPPER ALLOY.
- SPECIFICATION
 - STORAGE TEMPERATURE:-20-70°C.
 - OPERATING TEMPERATURE:0-85°C.
 - CONTACT RESISTANCE:20mΩ max.
 - INSULATION RESISTANCE:1000MΩ min.
 - DIELECTRIC WITHSTANDING VOLTAGE:AC 500V PER MINUTE.
- PART NUMBER: DS1032
- PRODUCT NUMBER CODE:
DS1032- X X X X X X
 - X X X X X X — PACKING
 - A: TUBE
 - CONTACT PLATING
 - T1: Tin.
 - HOUSING COLOR
 - K: BLACK
 - N: BROWN
 - MOUNTING TYPE
 - D: V/T DIP
 - HOUSING MATERIAL
 - S: PPS
 - No.OF CONTACTS
 - 32

GENERAL TOLERANCE		ANGLE TOLERANCE		PROJECTION		TITLE	PLCC 32pin DIP SOCKET	
X.	±0.60	X.	±5°	UNITS	mm			
.X	±0.38	.X	±3°	SHEET SIZE	A4	SERIES	DS1032 SERIES	
.XX	±0.25	.XX	±2°	晨翔电子有限公司 CONNFLY CONNFLY ELECTRONIC CO. LTD				
DRAWING TYPE		CUSTOMER						
SCALE	1:1	SHEET	1 OF 1					
DRAWING NO.		C-DS1032-32XXXXX						

FOR 32pin ONLY

REV.	DESCRIPTION	DRAWN	CHECKED	APPROVED
A	NEW RELEASE	DMJ 07/18/07'	~	LJC 07/17/07'
B	Change The P/N.	YCH 08/04/07'	~	LJC 08/04/07'
C	Change The DIM E For 44p	YCH 11/25/09'	~	LJC 11/25/09'

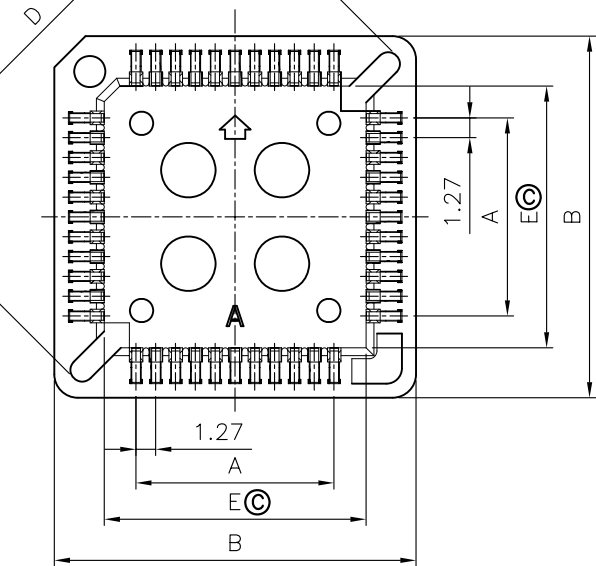

Dimension

Position	A±0.2	B±0.4	C±0.2	D±0.2	E±0.2
20	5.08	15.56	10.16	18.46	9.16
28	7.62	18.10	12.70	22.05	11.70
44	12.70	23.18	17.78	29.24	17.18
52	15.24	25.72	20.32	32.83	19.32
68	20.32	30.80	25.40	40.02	24.40
84	25.40	35.88	30.48	47.20	29.48

NOTES:

- MATERIAL
 - INSULATOR:THERMOPLASTIC(UL 94V-0).
 - CONTACT: COPPER ALLOY.
- SPECIFICATION
 - STORAGE TEMPERATURE:-20-70°C.
 - OPERATING TEMPERATURE:0-85°C.
 - CONTACT RESISTANCE:20mΩ max.
 - INSULATION RESISTANCE:1000MΩ min.
 - DIELECTRIC WITHSTANDING VOLTAGE:AC 500V PER MINUTE.
- PART NUMBER: DS1032
- PRODUCT NUMBER CODE:
DS1032- X X X X X X

- PACKING
- A: TUBE
- CONTACT PLATING
- T1: Tin.
- HOUSING COLOR
- K: BLACK
- N: BROWN
- MOUNTING TYPE
- D: V/T DIP
- HOUSING MATERIAL
- S: PPS
- No.OF CONTACTS
- 20 28 44
- 52 68 84

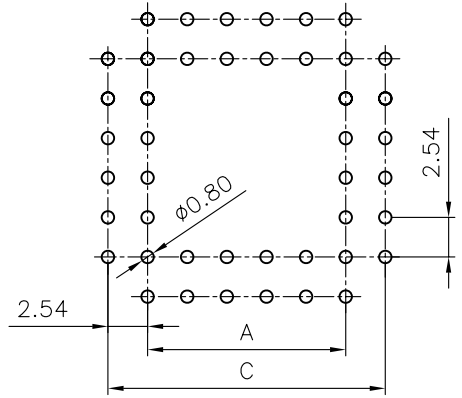
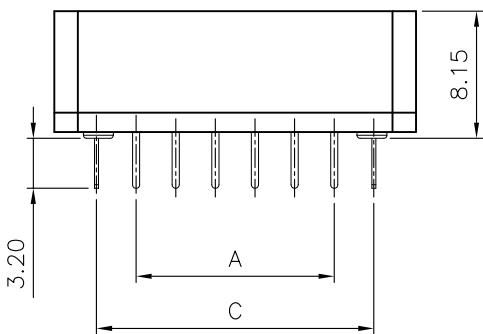

RECOMMEND PCB(V/T TYPE) LAYOUT
TOLERANCE=±0.05

GENERAL TOLERANCE	ANGLE TOLERANCE	PROJECTION	TITLE	PLCC 20/28/52/68/84pin DIP SOCKET
X. ±0.60	X. ±5°	UNITS	mm	
.X ±0.38	.X ±3°	SHEET SIZE	A4	SERIES DS1032 SERIES
.XX ±0.25	.XX ±2°	 晨翔电子有限公司 CONNFLY CONNFLY ELECTRONIC CO. LTD		
DRAWING TYPE	CUSTOMER			
SCALE	1:1 SHEET 1 OF 1			
DRAWING NO.	C-DS1032-XXXXXX			

REV.	DESCRIPTION	DRAWN	CHECKED	APPROVED
A	NEW RELEASE	YCH 11/13/07'		

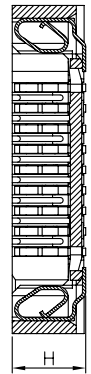
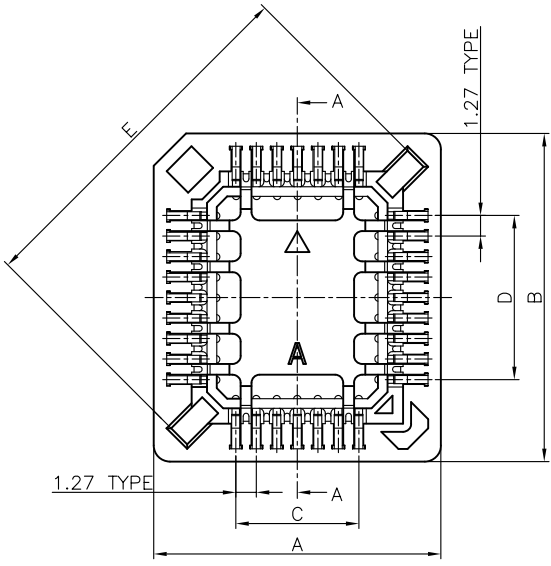

SECTION A-A

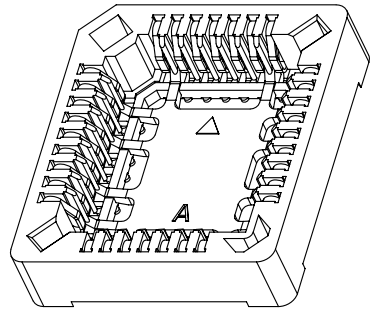

NOTES:

- MATERIAL
 - INSULATOR: THERMOPLASTIC,PPS CLASS FIRBER FILLED(UL 94V-0).
 - CONTACT: PHOSPHOR BRONZE.
- SPECIFICATION
 - STORAGE TEMPERATURE:-20-70°C.
 - OPERATING TEMPERATURE:0-85°C.
 - CONTACT RESISTANCE:20mΩ max.
 - INSULATION RESISTANCE:1000MΩ min.
 - DIELECTRIC WITHSTANDING VOLTAGE:AC 500V PER MINUTE.
- PART NUMBER: DS1032 SMT TYPE
- PRODUCT NUMBER CODE:

DS1032- X X X X X X X

- PACKING
- A: TUBE
- R: TAPE ON REEL
- PROFILE HEIGHT(DIM H)
- 1: 3.81mm
- S: 4.3mm
- L: 4.6mm
- CONTACT PLATING
- T1: Tin.
- HOUSING COLOR
- K: BLACK
- N: BROWN
- MOUNTING TYPE
- S: SMT
- HOUSING MATERIAL
- S: PPS
- No.OF CONTACTS
- 20 28 32 44
- 52 68 84

Dimension

Position	A±0.2	B±0.4	C±0.2	D±0.2	E±0.2
20	15.24	15.24	5.08	5.08	16.70
28	17.78	17.78	7.62	7.62	20.30
32	17.78	20.32	7.62	10.16	22.50
44	22.86	22.86	12.70	12.70	27.50
52	25.40	25.40	15.24	15.24	31.10
68	30.82	30.82	20.32	20.32	38.30
84	35.90	35.90	25.40	25.40	45.50

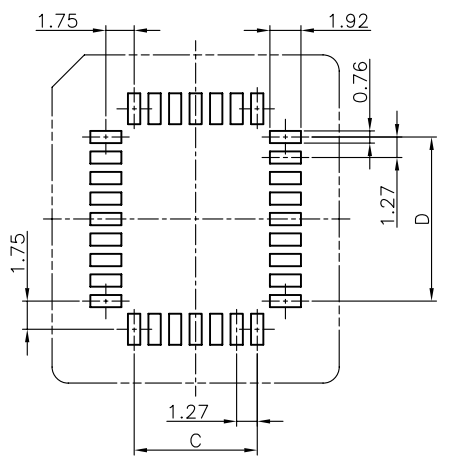

RECOMMEND PCB LAYOUT TOLERANCE=±0.05

GENERAL TOLERANCE	ANGLE TOLERANCE	PROJECTION		TITLE	PLCC SOCKET SMT TYPE	
X. ±0.60	X. ±5°	UNITS	mm			
.X ±0.38	.X ±3°	SHEET SIZE	A4	SERIES	DS1032 SERIES	
.XX ±0.25	.XX ±2°					
DRAWING TYPE	CUSTOMER					
SCALE	1:1	SHEET	1 OF 1			
DRAWING NO.	C-DS1032-XSSXXXX-A					

晨翔电子有限公司
CONFLY CONFLY ELECTRONIC CO. LTD