

REV.	DESCRIPTION	DRAWN	CHECKED	APPROVED
A	NEW RELEASE	LL 09/25/06'		

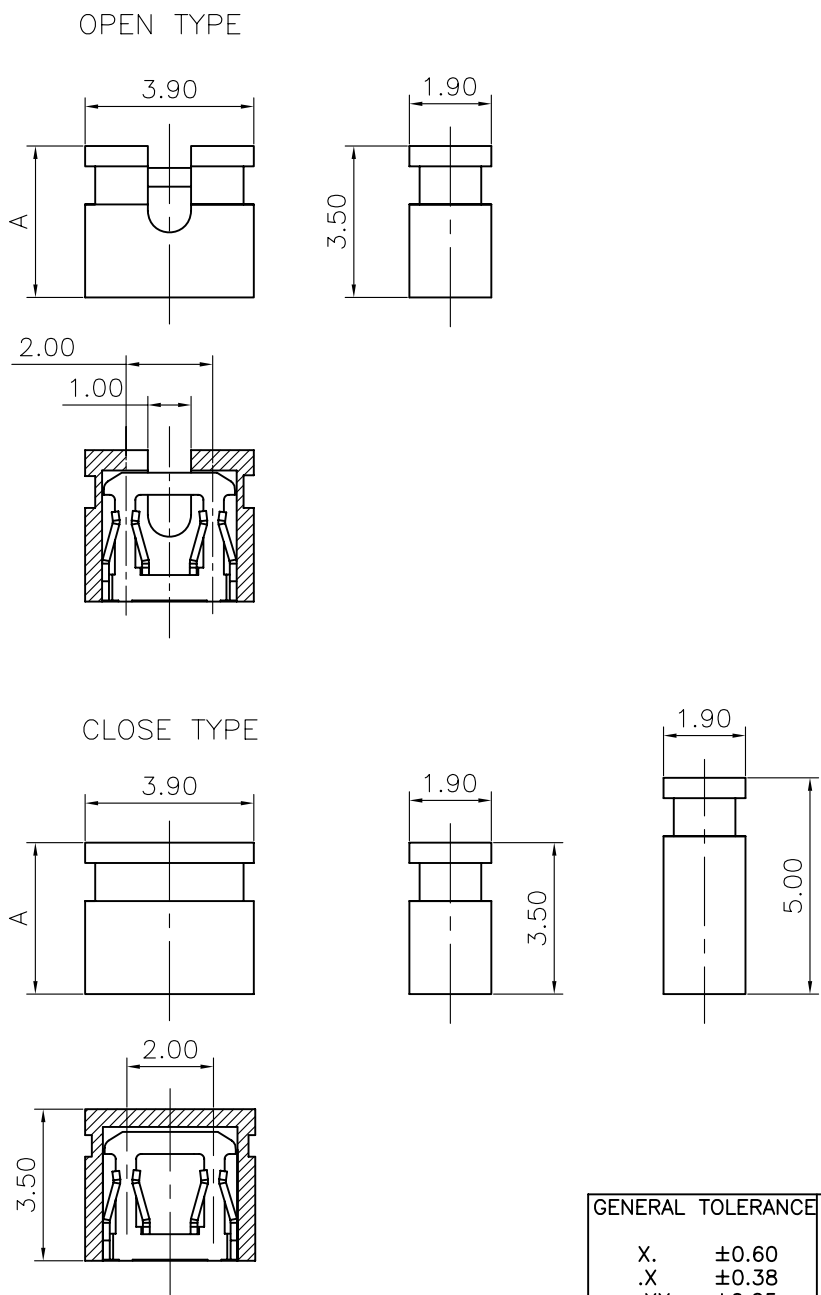

NOTES:

- SPECIFICATION:
 - CONTACT RESISTANCE: 30mΩ MAX.
 - DIELECTRIC WITHSTANDING VOLTAGE: 250V AC(rms) FOR 1 MINUTE.
 - INSULATION RESISTANCE: 500MΩ MINI.
 - OPERATING TEMPERATURE: -40°C~+105°C.

2. PRODUCT NUMBER CODE:

DS1028 - X X X X X

PROFILE HEIGHT(DIM A):
 1: 3.50mm
 2: 5.00mm

 CONTACT PLATING:
 F1: FULL GOLD FLASH
 N: NICKEL
 2: GOLD+NICKEL

 HOUSING COLOR:
 B: BLACK U:BLUE Y:YELLOW
 W: WHITE E:GREEN R:RED

 HOUSING TYPE:
 A:OPEN B:CLOSE

 No.OF CONTACTS:
 2: 2pin

 SERIES No:
 DS1028

GENERAL TOLERANCE		ANGLE TOLERANCE		PROJECTION		TITLE	MINI JUMPER PITCH 2.00mm	
X.	±0.60	X.	±5°	UNITS	mm			
.X	±0.38	.X	±3°	SHEET SIZE	A4	SERIES	DS1028 SERIES	
.XX	±0.25	.XX	±2°	 晨翔电子有限公司 CONNFLY CONNFLY ELECTRONIC CO. LTD				
DRAWING TYPE		CUSTOMER						
SCALE	1:1	SHEET	1 OF 1					
DRAWING NO.	C-DS1028-XXXXX							

REV.	DESCRIPTION	DRAWN	CHECKED	APPROVED
A	NEW RELEASE	LJC 08/16/07'		

NOTES:

1. SPECIFICATION:

- 1.1 CONTACT RESISTANCE: 30mΩ MAX.
- 1.2 DIELECTRIC WITHSTANDING VOLTAGE: 250V AC(rms) FOR 1 MINUTE.
- 1.3 INSULATION RESISTANCE: 500MΩ Min.
- 1.4 OPERATING TEMPERATURE: -40°C~+105°C.

2. PRODUCT NUMBER CODE:

DS1028-01 - X X X X X

- PROFILE HEIGHT(DIM A): 3:4.30mm
- CONTACT PLATING:
F1: FULL GOLD FLASH
N: NICKEL
2: GOLD+NICKEL
- HOUSING COLOR:
B: BLACK U:BLUE Y:YELLOW
W: WHITE E:GREEN R:RED
- HOUSING TYPE:
A:OPEN
B:CLOSE
- No.OF PORTS:
3: 3ports 8: 8ports
4: 4ports 9: 9ports
5: 5ports 10: 10ports
6: 6ports
7: 7ports
- SERIES No:
DS1028-01

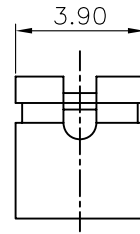
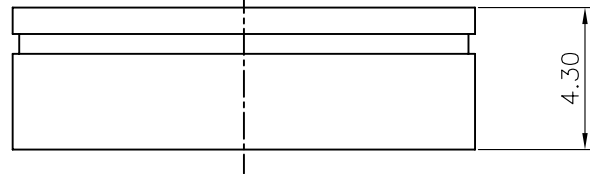

OPEN TYPE

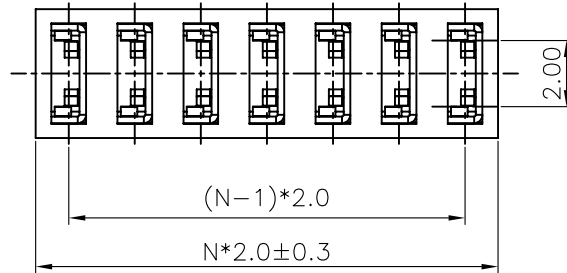

N=Number of Ports

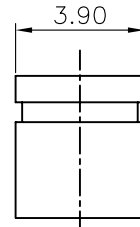

CLOSE TYPE

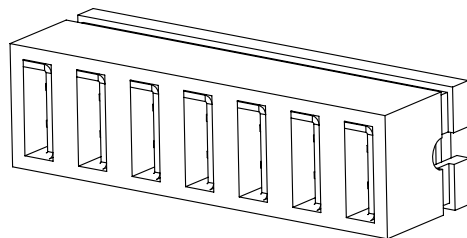

GENERAL TOLERANCE		ANGLE TOLERANCE	
X.	±0.60	X.	±5°
.X	±0.38	.X	±3°
.XX	±0.25	.XX	±2°

PROJECTION	TITLE	2.00mm pitch MINI JUMPER	
UNITS	mm	Stack type 3-10 ports	
SHEET SIZE	A4	SERIES	DS1028-01 SERIES

DRAWING TYPE	CUSTOMER		
SCALE	1:1	SHEET	1 OF 1
DRAWING NO.	C-DS1028-01-XXXXX		

 晨翔电子有限公司
CONNFLY CONNFLY ELECTRONIC CO. LTD

REV.	DESCRIPTION	DRAWN	CHECKED	APPROVED
A	NEW RELEASE	LL 12/04/06'		

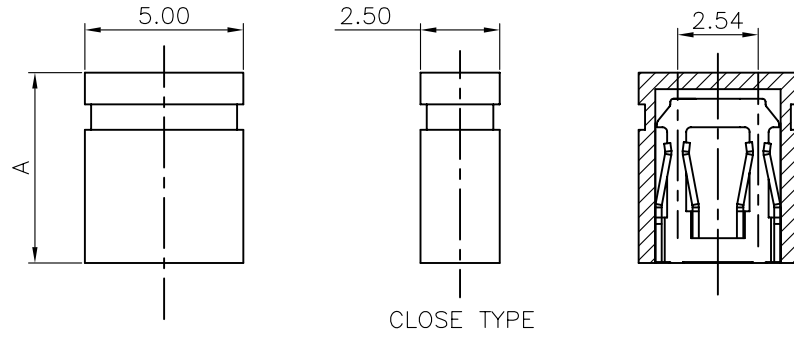

CLOSE TYPE

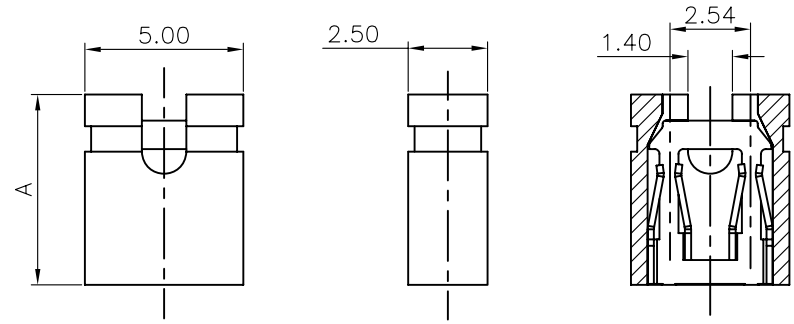

OPEN TYPE

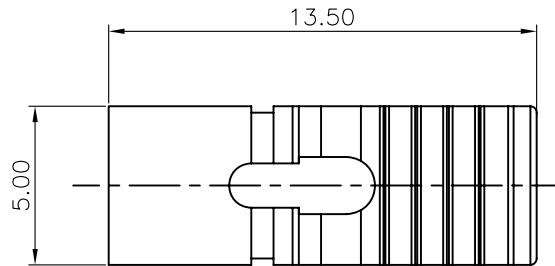

LONG TYPE

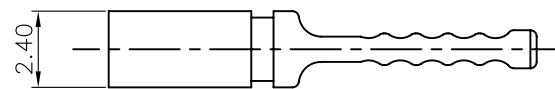

NOTES:

1. SPECIFICATION:

- 1.1 CONTACT RESISTANCE: 30mΩ MAX.
- 1.2 DIELECTRIC WITHSTANDING VOLTAGE: 250V AC(rms) FOR 1 MINUTE.
- 1.3 INSULATION RESISTANCE: 500MΩ Min.
- 1.4 OPERATING TEMPERATURE: -40°C~+105°C.

2. PRODUCT NUMBER CODE:

DS1027 - X X X X X

PROFILE HEIGHT(DIM A):
0:6.0mm
1:6.47mm

CONTACT PLATING:
F1: FULL GOLD FLASH
N: NICKEL
2: GOLD+NICKEL

HOUSING COLOR:
B: BLACK U:BLUE Y:YELLOW
W: WHITE E:GREEN R:RED

HOUSING TYPE:
A:OPEN B:CLOSE L:Long

No.OF CONTACTS:
2: 2pin

SERIES No:
DS1027

GENERAL TOLERANCE		ANGLE TOLERANCE	
X.	±0.60	X.	±5°
.X	±0.38	.X	±3°
.XX	±0.25	.XX	±2°

PROJECTION		TITLE	MINI JUMPER PITCH 2.54mm
UNITS	mm		
SHEET SIZE	A4	SERIES	DS1027 SERIES

DRAWING TYPE	CUSTOMER		
SCALE	1:1	SHEET	1 OF 1
DRAWING NO.	C-DS1027-XXXXX		

晨翔电子有限公司
CONNFLY CONNFLY ELECTRONIC CO. LTD

REV.	DESCRIPTION	DRAWN	CHECKED	APPROVED
A	NEW RELEASE	LL 12/04/06'		

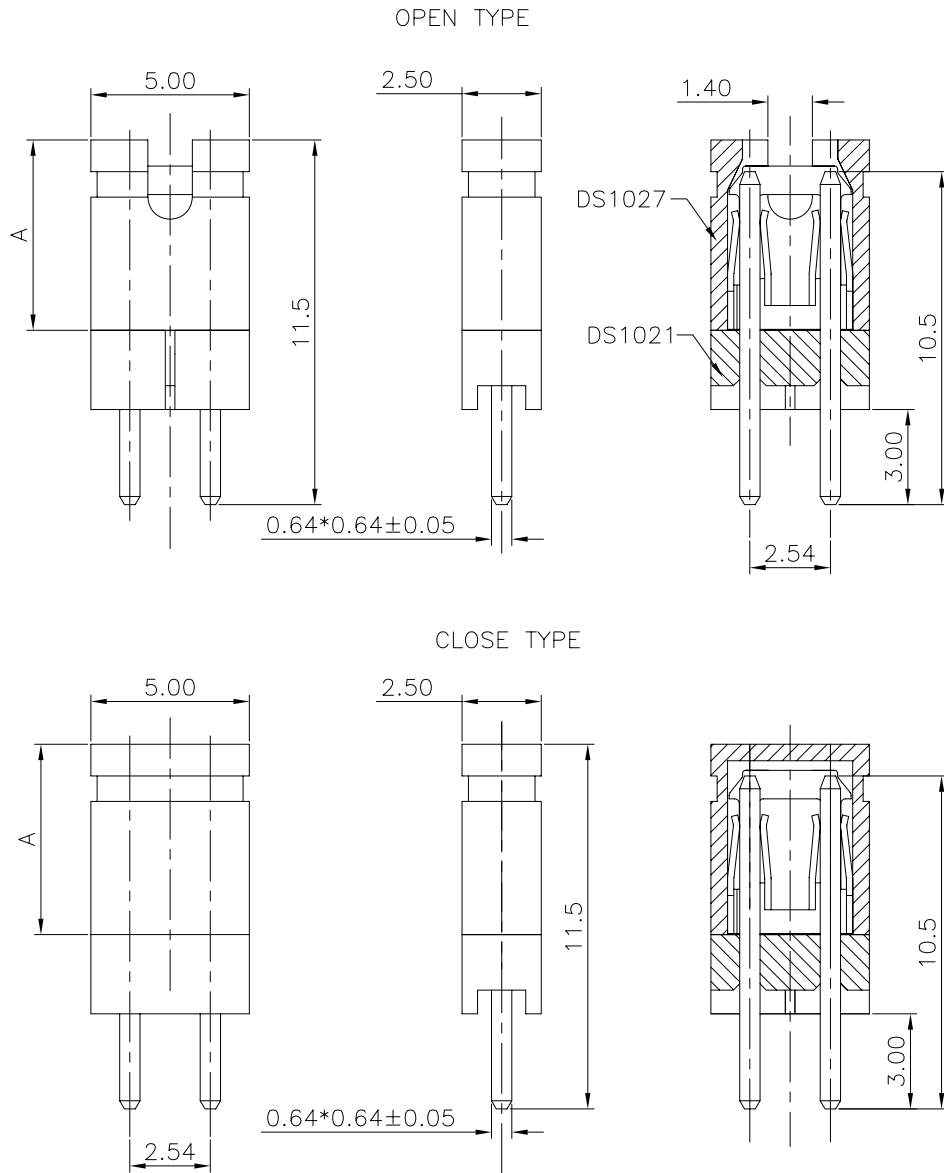

NOTES:

1. SPECIFICATION:

- 1.1 CONTACT RESISTANCE: 30mΩ MAX.
- 1.2 DIELECTRIC WITHSTANDING VOLTAGE: 250V AC(rms) FOR 1 MINUTE.
- 1.3 INSULATION RESISTANCE: 500MΩ Min.
- 1.4 OPERATING TEMPERATURE: -40°C~+105°C.

2. PRODUCT NUMBER CODE:

DS1027-01-X X X X X X

CONNECTOR Q'TY
1: 2 CONNECTOR
1PCS DS1021; 1PCS DS1027

PROFILE HEIGHT(DIM A):
0:6.0mm

CONTACT PLATING:
8: FULL GOLD FLASH

HOUSING COLOR:
B: BLACK

HOUSING TYPE:
A:OPEN B:CLOSE

No.OF CONTACTS:
2: 2pin

GENERAL TOLERANCE		ANGLE TOLERANCE	
X.	±0.60	X.	±5°
.X	±0.38	.X	±3°
.XX	±0.25	.XX	±2°

PROJECTION	TITLE
UNITS	2.54 MINI JUMPER WITH PIN HEADER
SHEET SIZE	SERIES DS1027-01 SERIES

DRAWING TYPE	CUSTOMER
SCALE	1:1 SHEET 1 OF 1
DRAWING NO.	C-DS1027-01-XXXXXX

晨翔电子有限公司
CONNFLY CONNFLY ELECTRONIC CO. LTD

REV.	DESCRIPTION	DRAWN	CHECKED	APPROVED
A	NEW RELEASE	LJC 08/16/07'		

NOTES:

1. SPECIFICATION:

- 1.1 CONTACT RESISTANCE: 30mΩ MAX.
- 1.2 DIELECTRIC WITHSTANDING VOLTAGE: 250V AC(rms) FOR 1 MINUTE.
- 1.3 INSULATION RESISTANCE: 500MΩ Min.
- 1.4 OPERATING TEMPERATURE: -40°C~+105°C.

2. PRODUCT NUMBER CODE:

DS1027-02 - X X X X X

- PROFILE HEIGHT(DIM A): 0:6.0mm
- CONTACT PLATING:
F1: FULL GOLD FLASH
N: NICKEL
2: GOLD+NICKEL
- HOUSING COLOR:
B: BLACK U:BLUE Y:YELLOW
W: WHITE E:GREEN R:RED
- HOUSING TYPE:
A:OPEN
B:CLOSE
- No.OF PORTS:
3: 3ports 8: 8ports
4: 4ports 9: 9ports
5: 5ports 10: 10ports
6: 6ports
7: 7ports
- SERIES No:
DS1027-02

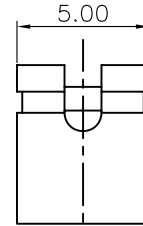
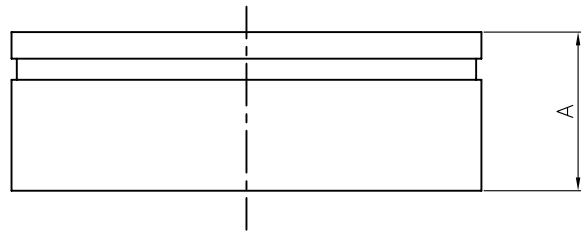

OPEN TYPE

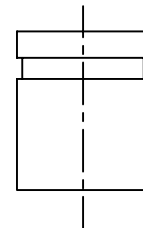
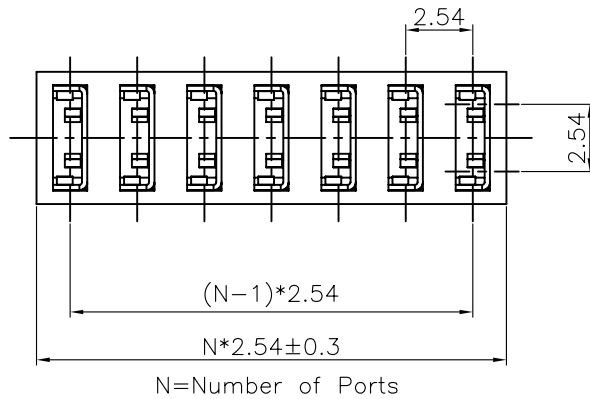

CLOSE TYPE

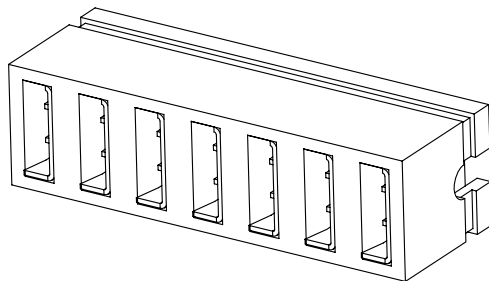

GENERAL TOLERANCE		ANGLE TOLERANCE		PROJECTION		TITLE	2.54mm pitch MINI JUMPER Stack type 3-10 ports	
X.	±0.60	X.	±5°	UNITS	mm			
.X	±0.38	.X	±3°	SHEET SIZE	A4	SERIES	DS1027-02 SERIES	
.XX	±0.25	.XX	±2°	晨翔电子有限公司 CONNFLY CONNFLY ELECTRONIC CO. LTD				
DRAWING TYPE		CUSTOMER						
SCALE	1:1	SHEET	1 OF 1					
DRAWING NO.		C-DS1027-02-XXXXX						