

REV.	DESCRIPTION	DRAWN	CHECKED	APPROVED
A	NEW RELEASE	LL 09/25/06'	~	LJC 09/25/06'
B	整理图面	YCH 05/21/08'	~	

NOTES:

- ELECTRICAL CHARACTERISTICS:
 - CONTACT RESISTANCE: 20mΩ Max. INITIAL.
 - DIELECTRIC WITHSTANDING VOLTAGE: 500V AC(rms) FOR 1 MINUTE.
 - INSULATION RESISTANCE: 1000MΩ Min.
- ENVIRONMENT CHARACTERISTICS:
 - OPERATING TEMPERATURE: -40°C~+105°C.
- PRODUCT NUMBER CODE:

DS1077- X X X X X X

- SCREW DIM. A
 - S: Standard(W/O nut)
 - 1: 5.00
 - 2: 3.00
 - 3: 5.20
 - 4: 4.80
 - 5: 5.80
 - 6: 4.00
- SCREW TYPE
 - S: Standard(W/O nut)
 - 1: CC TYPE
 - 2: CS TYPE
 - 3: BR TYPE
 - 4: BRJ TYPE DIM. DIM C: 3~4
 - 5: BRJ TYPE DIM. DIM C: 5~6
 - 6: BRJ TYPE DIM. DIM C: 3~4 (SCREWS IN BULK PACKAGE)
- SHELL PLATING
 - T:FORNT & BACK SHELL TIN
 - N:FORNT SHELL NICKEL,BACK SHELL TIN
- CONTACT PLATING
 - 8: FULL GOLD FLASH
 - 0: SELECTIVE GOLD FLASH
- HOUSING COLOR
 - B:BLACK
 - W:WHITE
 - U:BLUE
- CONNECTOR TYPE
 - M:MALE
 - F:FEMALE
- No.OF CONTACTS
 - 15 26 44 62 78

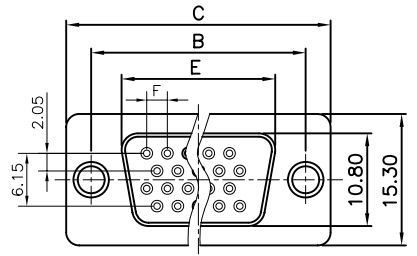
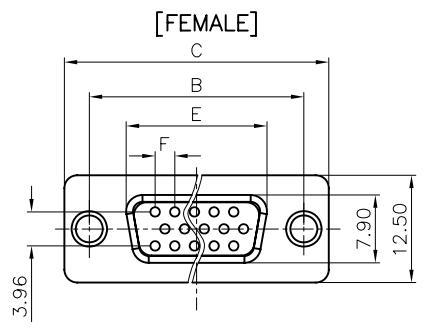

Standard TYPE

78pin Figure

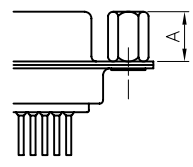
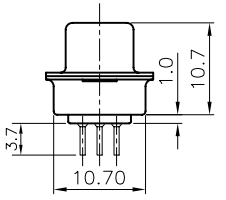
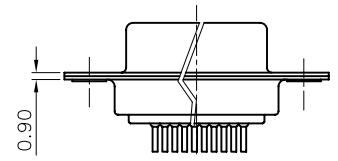

CC TYPE

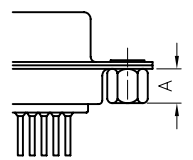

CS TYPE

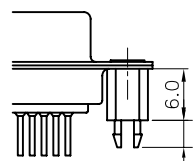

BR TYPE

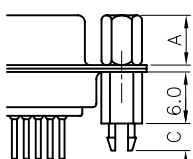

BRJ TYPE

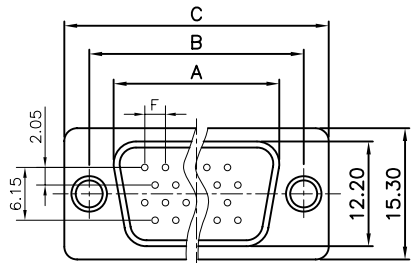
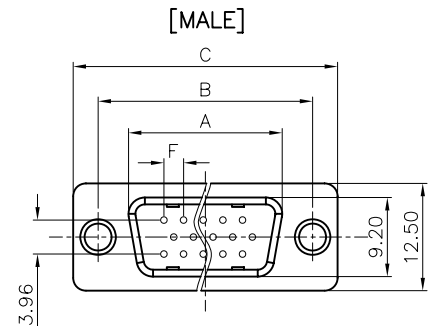

78pin Figure

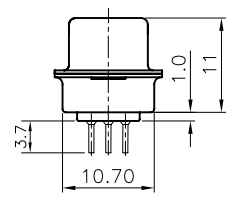
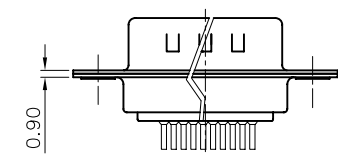

Dimension

Position	A	B	C	E	F
15	17.90	24.99	30.80	16.33	2.29
26	26.50	33.32	39.14	24.66	2.29
44	40.00	47.04	53.04	38.38	2.29
62	56.50	63.50	69.32	54.84	2.41
78	54.30	61.00	67.04	52.34	2.41

GENERAL TOLERANCE	ANGLE TOLERANCE
X. ±0.60	X. ±5°
.X ±0.38	.X ±3°
.XX ±0.25	.XX ±2°

PROJECTION	TITLE
	D-SUB H.DIP STRAIGHT TYPE
UNITS	mm
SHEET SIZE	A4
SERIES	DS1077 SERIES

DRAWING TYPE	CUSTOMER
SCALE	1:1 SHEET 1 OF 1
DRAWING NO.	C-DS1077-XXXXXXX

晨翔电子有限公司
CONNFLY CONNFLY ELECTRONIC CO. LTD

REV.	DESCRIPTION	DRAWN	CHECKED	APPROVED
A	NEW RELEASE	LJH 09/27/05'		
B	增加螺丝类型 D	L L 06/06/06'		

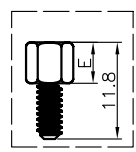
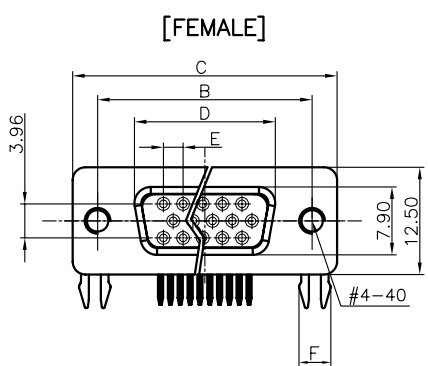

SCREWS

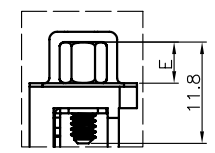

WITH SCREW TYPE

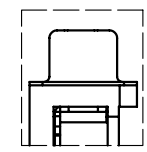
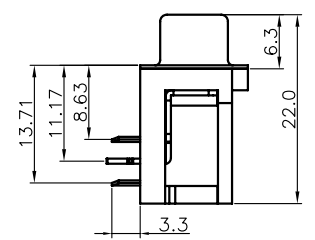
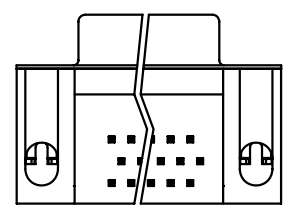

WITH RIVET TYPE

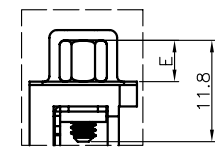
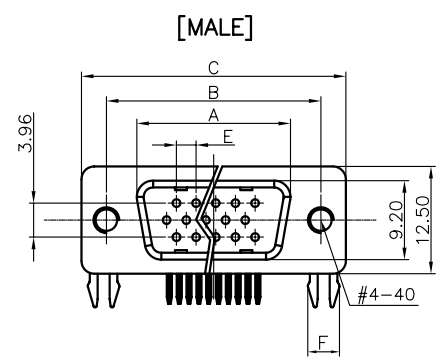

RIVET TYPE WITH FIXED SCREWS

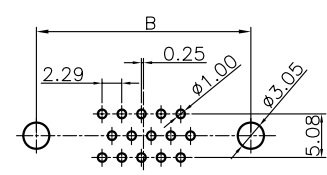
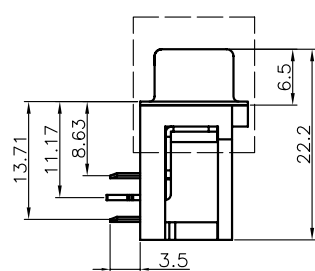
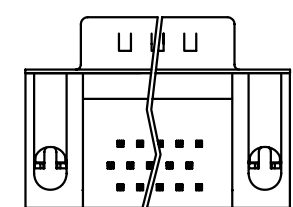

RECOMMEND PCB LAYOUT(TOLERANCE ±0.05)
(VIEW FROM TOP SIDE)

NOTES:

- PRODUCTS PERFORMANCE:
 - VOLTAGE RATING: 250V AC.
 - CONTACT CURRENT RATING: 1.5A MAX. PER PIN.
 - CONTACT RESISTANCE: 20mΩ MAX.
 - DIELECTRIC WITHSTANDING VOLTAGE: 500V AC(rms) FOR 1 MINUTE.
 - INSULATION RESISTANCE: 1000MΩ MIN.
 - TEMPERATURE RANGE: -40°C~+105°C.

2. PRODUCT NUMBER CODE:

DS1038 - X X X X X X X X

- SCREW DIM. E
 - 4: 4.80mm
 - 5: 5.80mm
- BOARD LOCK DIM. F
 - 4: 4.00mm
 - 7: 3.70mm
- SCREW TYPE
 - A: WITH SCREW TYPE
 - B: WITH RIVET TYPE
 - C: RIVET TYPE WITH FIXED SCREWS
 - D: RIVET TYPE WITH SCREWS IN BULK PACKAGE
- CONTACT PLATING
 - Si: SELECTIVE GOLD FLASH
 - 8: FULL GOLD FLASH
 - 6: FULL TIN
- SHELL PLATING
 - N: Nickel
 - T: Tin
- COLOR OF HOUSING
 - Y: Yellow
 - B: BLACK
 - U: BLUE
 - C: BLUE(PC99)
- CONNECTOR TYPE
 - M: MALE
 - F: FEMALE
- No. OF CONTACTS
 - 15: 15pos.
 - 44: 44pos.
 - 26: 26pos.
 - 62: 62pos.

Dimension

Position	A±0.2	B±0.2	C±0.3	D	E
15	17.90	24.99	30.84	16.33	2.29
26	26.50	33.32	39.14	24.66	2.29
44	40.00	47.04	53.04	38.38	2.29
62	56.50	63.50	69.32	54.84	2.41

GENERAL TOLERANCE		ANGLE TOLERANCE	
X.	±0.60	X.	±5°
.X	±0.38	.X	±3°
.XX	±0.25	.XX	±2°

PROJECTION	TITLE	D-SUB H.D RIGHT ANGLE TYPE	
UNITS	mm		
SHEET SIZE	A4	SERIES	DS1038 SERIES

DRAWING TYPE	CUSTOMER		
SCALE	1:1	SHEET	1 OF 1
DRAWING NO.	C-DS1038-XXXXXXX		

晨翔电子有限公司
CONNFLY CONNFLY ELECTRONIC CO. LTD

REV.	DESCRIPTION	DRAWN	CHECKED	APPROVED
A	NEW RELEASE	YCH 06/12/08'	~	

NOTES:

- PRODUCTS PERFORMANCE:
 - VOLTAGE RATING: 250V AC.
 - CURRENT RATING: 1.5A MAX.
 - CONTACT RESISTANCE: 20mΩ MAX.
 - DIELECTRIC WITHSTANDING VOLTAGE: 500V AC(rms) FOR 1 MINUTE.
 - INSULATION RESISTANCE: 1000MΩ MINI.
 - OPERATING TEMPERATURE: -40°C~+105°C.
- PRODUCT NUMBER CODE:

DS1038-01 - X X X X X X X X

- SCREW DIM. G
- 4: 4.80mm
- 5: 5.80mm
- BOARD LOCK DIM. F
- 7: 3.70mm
- SCREW TYPE
- A: WITH SCREW TYPE
- B: WITH RIVET TYPE
- C: WITH SCREW AND RIVET TYPE
- CONTACT PLATING
- Si: SELECTIVE GOLD FLASH
- 8: FULL GOLD FLASH
- 6: FULL TIN
- SHELL PLATING
- N: Nickel
- T: Tin
- COLOR OF HOUSING
- B: BLACK
- U: BLUE
- C: BLUE(PC99)
- CONNECTOR TYPE
- M: MALE
- F: FEMALE
- No. OF CONTACT
- 15: 15pos.

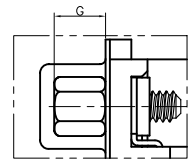
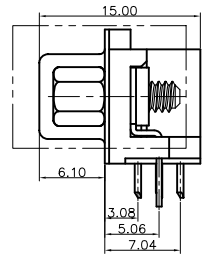
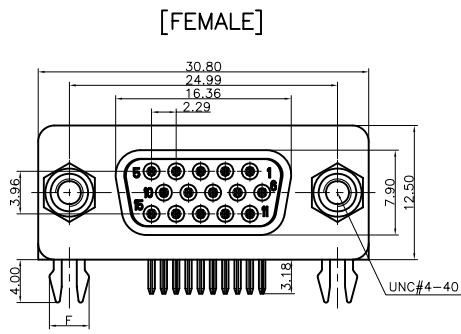

WITH SCREW AND RIVET TYPE

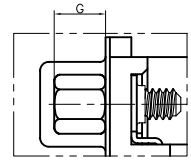

WITH SCREW TYPE

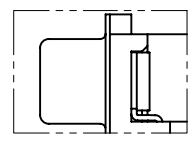

WITH RIVET TYPE

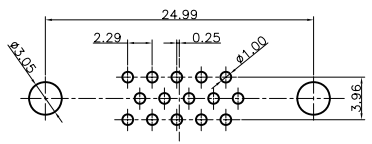

RECOMMEND PCB LAYOUT (TOLERANCE ±0.05)

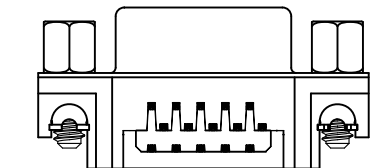

[MALE]

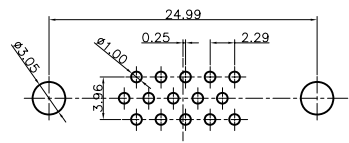
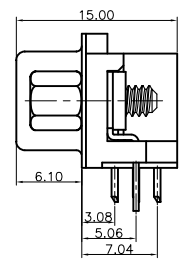
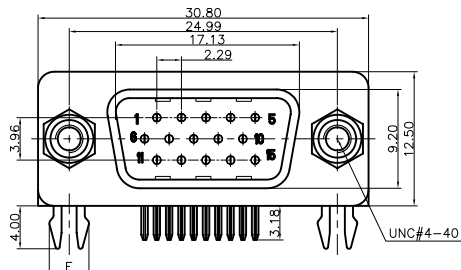

RECOMMEND PCB LAYOUT (TOLERANCE ±0.05)

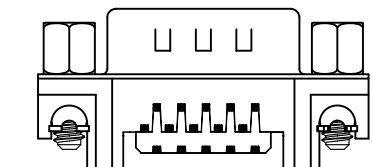

GENERAL TOLERANCE		ANGLE TOLERANCE	
X.	±0.60	X.	±5°
.X	±0.50	.X	±3°
.XX	±0.30	.XX	±2°

PROJECTION	TITLE
UNITS	D-SUB H.D RIGHT ANGLE 3.08mm TYPE
SHEET SIZE	SERIES DS1038-01 SERIES

DRAWING TYPE	CUSTOMER
SCALE	1:1 SHEET 1 OF 1
DRAWING NO.	C-DS1038-01-XXXXXXXXXX

晨翔电子有限公司
CONNFLY CONNFLY ELECTRONIC CO. LTD

REV.	DESCRIPTION	DRAWN	CHECKED	APPROVED
A	NEW RELEASE	YCH 12/15/09'		

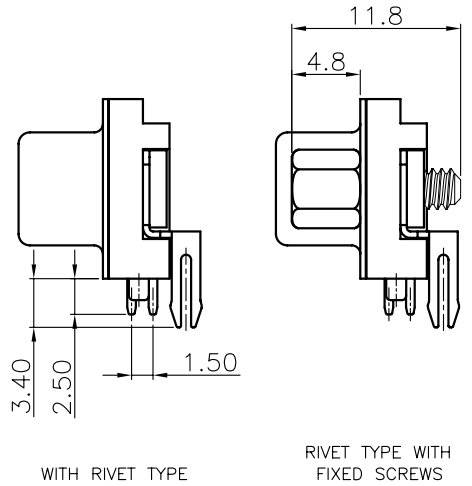
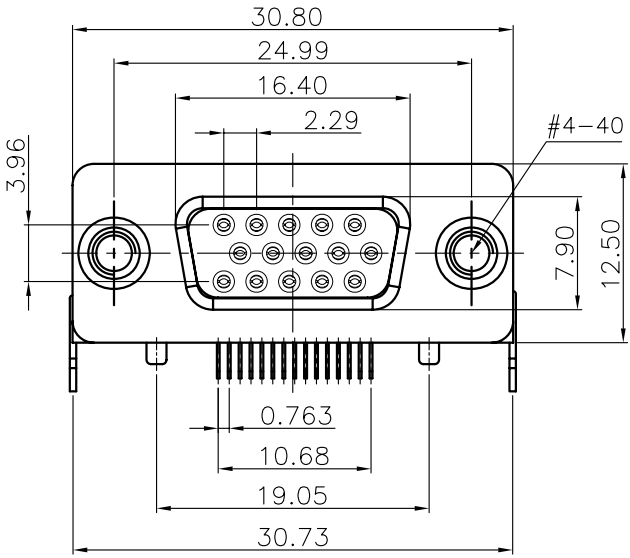

NOTES:

- PRODUCTS PERFORMANCE:
 - VOLTAGE RATING: 250V AC.
 - CONTACT CURRENT RATING: 1.5A MAX. PER PIN.
 - CONTACT RESISTANCE: 20mΩ MAX.
 - DIELECTRIC WITHSTANDING VOLTAGE: 500V AC(rms) FOR 1 MINUTE.
 - INSULATION RESISTANCE: 1000MΩ MIN.
 - TEMPERATURE RANGE: -40°C~+105°C.
- PRODUCT NUMBER CODE:

DS1038-*03 - X X X X X X

- SCREW TYPE
- B: WITH RIVET TYPE
- C: RIVET TYPE WITH FIXED SCREWS
- D: RIVET TYPE WITH SCREWS IN BULK PACKAGE
- CONTACT PLATING
- Si: SELECTIVE GOLD FLASH
- 8: FULL GOLD FLASH
- SHELL PLATING
- N: Nickel
- T: Tin
- COLOR OF HOUSING
- B: BLACK
- W: WHITE
- L: BLUE
- CONNECTOR TYPE
- F: FEMALE
- No. OF CONTACTS
- 15: 15pos.

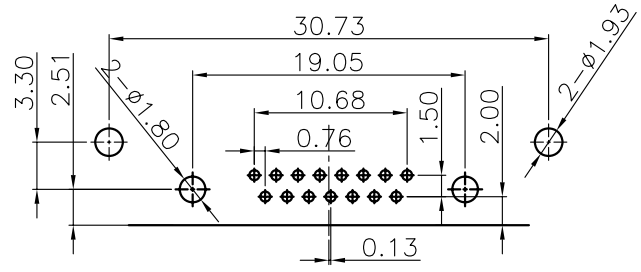
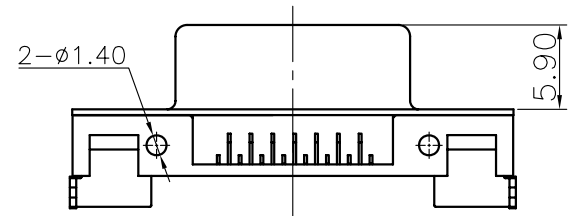

RECOMMEND PCB LAYOUT
(TOLERANCE ±0.05)

GENERAL TOLERANCE		ANGLE TOLERANCE		PROJECTION		TITLE	D-SUB H.D RIGHT ANGLE SLIM TYPE	
X.	±0.60	X.	±5°	UNITS	mm	SERIES	DS1038-03 SERIES	
.X	±0.38	.X	±3°	SHEET SIZE	A4			
.XX	±0.25	.XX	±2°	晨翔电子有限公司 CONNFLY CONNFLY ELECTRONIC CO. LTD				
DRAWING TYPE		CUSTOMER						
SCALE	1:1	SHEET	1 OF 1					
DRAWING NO.		C-DS1038-03-XXXXXX						

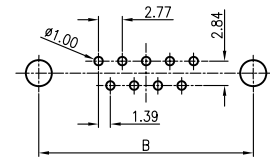
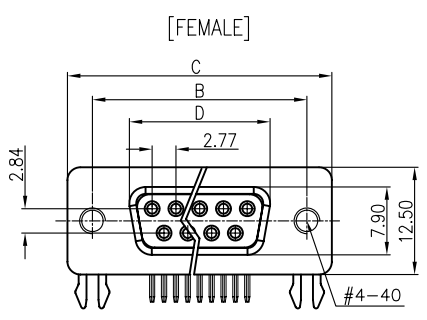

RECOMMEND PCB LAYOUT(TOLERANCE ± 0.05)
(VIEW FROM TOP SIDE)

REV.	DESCRIPTION	DRAWN	CHECKED	APPROVED
A	NEW RELEASE	LJH 05/13/06'		LJC 05/13/06'
E	ADD SCREW TYPE	YCH 05/28/09'		

NOTES:

- PRODUCTS PERFORMANCE:
 - VOLTAGE RATING: 250V AC.
 - CONTACT CURRENT RATING: 1.5A MAX. PER PIN.
 - CONTACT RESISTANCE: 20m Ω MAX.
 - DIELECTRIC WITHSTANDING VOLTAGE: 500V AC(rms) FOR 1 MINUTE.
 - INSULATION RESISTANCE: 1000M Ω MINI.
 - TEMPERATURE RANGE: -40°C~+105°C.
- PRODUCT NUMBER CODE:
DS1037 - X X X X X X X X
 - SCREW DIM. E
 - 4: 4.80mm
 - 5: 5.80mm
 - 6: 4.80mm(inside thread M2.6*0.45p, outside thread unc#4-40)
 - M3: 4.80mm(inside thread M3.0, outside thread unc#4-40)
 - BOARD LOCK DIM. F
 - 4: 4.00mm
 - 7: 3.70mm
 - CONTACT PLATING
 - T: SELECTIVE GOLD FLASH
 - Si: FULL GOLD FLASH
 - 6: FULL TIN
 - 1: SELECTIVE 10u" GOLD
 - COLOR OF HOUSING
 - K: BLACK
 - B: BLUE
 - SCREW TYPE
 - A: WITH SCREW TYPE
 - B: WITH RIVET TYPE
 - C: WITH SCREW AND RIVET TYPE
 - D: RIVET TYPE WITH SCREWS IN BULK PACKAGE
 - E: WITH RIVET TYPE(N/A THREAD)
 - SHELL PLATING
 - N: Nickel
 - T: Tin
 - CONNECTOR TYPE
 - M: MALE
 - F: FEMALE
 - No. OF CONTACT
 - 09: 9pos. 25: 25pos.
 - 15: 15pos. 37: 37pos.

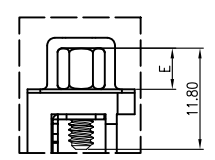
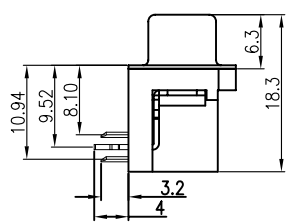
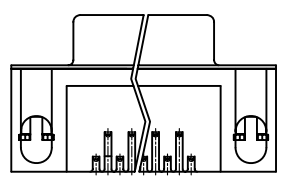

WITH SCREW TYPE

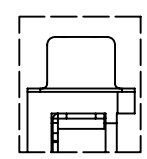
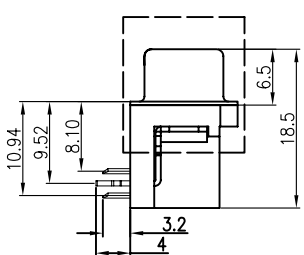
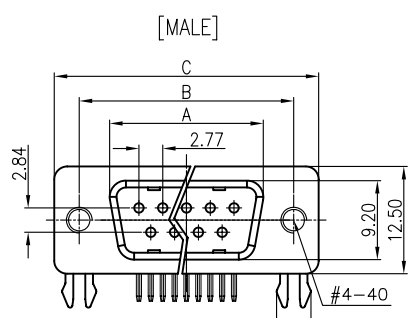

WITH RIVET TYPE

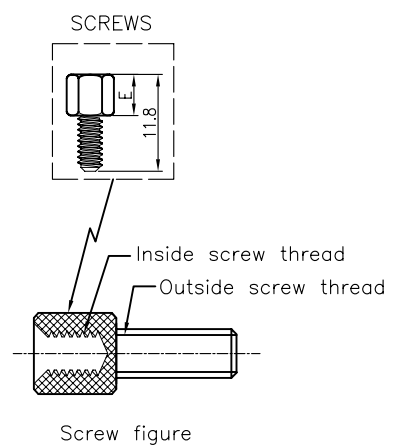

WITH SCREW AND RIVET TYPE

Dimension

Position	A ± 0.2	B ± 0.2	C ± 0.2	D
9	17.90	24.99	30.84	16.33
15	26.50	33.32	39.14	24.66
25	40.00	47.04	53.04	38.38
37	56.50	63.50	69.32	54.84

GENERAL TOLERANCE		ANGLE TOLERANCE	
X.	± 0.60	X.	$\pm 5'$
.X	± 0.38	.X	$\pm 3'$
.XX	± 0.25	.XX	$\pm 2'$
DRAWING TYPE		CUSTOMER	
SCALE		1:1	SHEET 1 OF 1
DRAWING NO.		C-DS1037-XXXXXXX	

PROJECTION		TITLE
UNITS	mm	D-SUB RIGHT ANGLE(7.2mm) TYPE
SHEET SIZE	A4	SERIES DS1037 SERIES

晨翔电子有限公司
CONFLY CONFLY ELECTRONIC CO. LTD

REV.	DESCRIPTION	DRAWN	CHECKED	APPROVED
A	NEW RELEASE	YCH 08/13/07'	~	

NOTES:

- PRODUCTS PERFORMANCE:
 - VOLTAGE RATING: 250V AC.
 - CONTACT CURRENT RATING: 1.5A MAX. PER PIN.
 - CONTACT RESISTANCE: 20mΩ MAX.
 - DIELECTRIC WITHSTANDING VOLTAGE: 500V AC(rms) FOR 1 MINUTE.
 - INSULATION RESISTANCE: 1000MΩ MINI.
 - OPERATING TEMPERATURE: -40°C~+105°C.
- PRODUCT NUMBER CODE:

DS1037-02 - X X X X X X X X

- SCREW DIM. E
 - 4: 4.80mm
 - 5: 5.80mm
- BOARD LOCK DIM. F
 - 4: 4.00mm
 - 7: 3.70mm
- CONTACT PLATING
 - T: SELECTIVE GOLD FLASH
 - Si: FULL GOLD FLASH
 - 6: FULL TIN
- COLOR OF HOUSING
 - K: BLACK
 - B: BLUE
- SCREW TYPE
 - A: WITH SCREW TYPE
 - C: WITH SCREW AND RIVET TYPE
- SHELL PLATING
 - N: Nickel
 - T: Tin
- CONNECTOR TYPE
 - M: MALE
 - F: FEMALE
- No. OF CONTACT
 - 09: 9pos.
 - 15: 15pos.
 - 25: 25pos.
 - 37: 37pos.

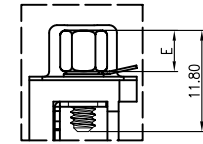
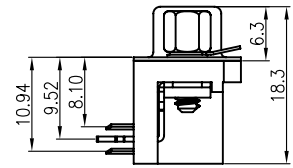
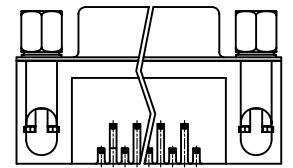
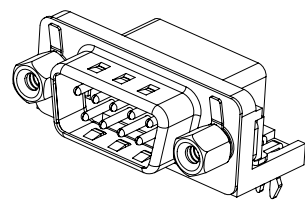
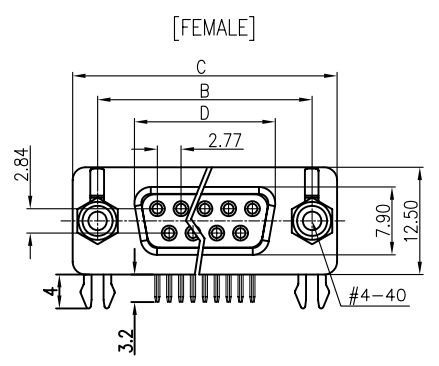

WITH SCREW TYPE

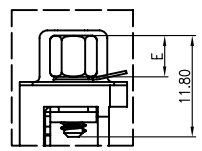
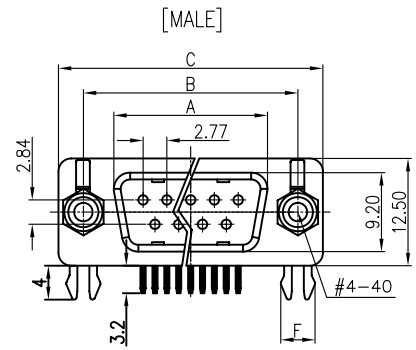

WITH SCREW AND RIVET TYPE

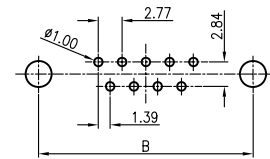
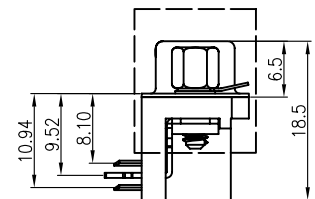
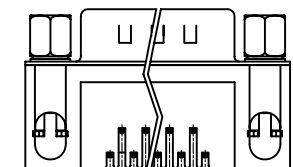

RECOMMEND PCB LAYOUT(TOLERANCE ±0.05)
(VIEW FROM TOP SIDE)

Dimension

Position	A±0.2	B±0.2	C±0.2	D
9	17.90	24.99	30.84	16.33
15	26.50	33.32	39.14	24.66
25	40.00	47.04	53.04	38.38
37	56.50	63.50	69.32	54.84

GENERAL TOLERANCE		ANGLE TOLERANCE	
X.	±0.60	X.	±5°
.X	±0.38	.X	±3°
.XX	±0.25	.XX	±2°
DRAWING TYPE		CUSTOMER	
SCALE		1:1	SHEET 1 OF 1
DRAWING NO.		C-DS1037-02-XXXXXXX	

PROJECTION	TITLE
	D-SUB RIGHT ANGLE(7.2mm)WITH SHIELDING TYPE
UNITS	mm
SHEET SIZE	A4
SERIES	DS1037-02 SERIES

晨翔电子有限公司
CONNFLY CONNFLY ELECTRONIC CO. LTD

REV.	DESCRIPTION	DRAWN	CHECKED	APPROVED
A	NEW RELEASE	YCH 08/13/07'	~	

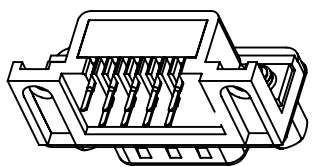
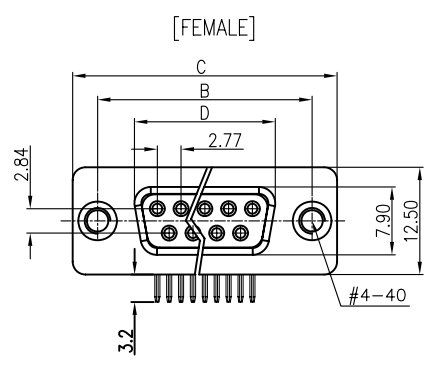

NOTES:

- PRODUCTS PERFORMANCE:
 - VOLTAGE RATING: 250V AC.
 - CONTACT CURRENT RATING: 1.5A MAX. PER PIN.
 - CONTACT RESISTANCE: 20mΩ MAX.
 - DIELECTRIC WITHSTANDING VOLTAGE: 500V AC(rms) FOR 1 MINUTE.
 - INSULATION RESISTANCE: 1000MΩ MINI.
 - OPERATING TEMPERATURE: --40°C~+105°C.
- PRODUCT NUMBER CODE:

DS1037-03 - X X X X X X X

- SCREW DIM. E
4: 4.80mm
5: 5.80mm
- CONTACT PLATING
T: SELECTIVE GOLD FLASH
Si: FULL GOLD FLASH
6: FULL TIN
- COLOR OF HOUSING
K: BLACK
B: BLUE
- SCREW TYPE
B: WITH RIVET TYPE
C: WITH SCREW AND RIVET TYPE
D: RIVET TYPE WITH SCREWS IN BULK PACKAGE
- SHELL PLATING
N: Nickel
T: Tin
- CONNECTOR TYPE
M: MALE
F: FEMALE
- No. OF CONTACT
09: 9pos.
15: 15pos.
25: 25pos.
37: 37pos.

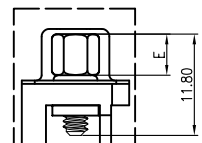
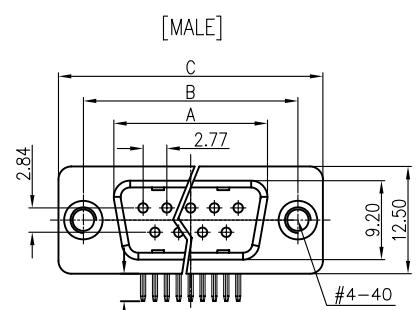
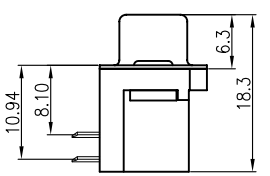
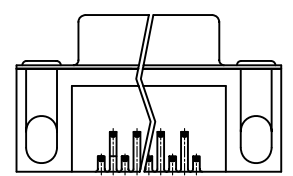

WITH SCREW AND RIVET TYPE

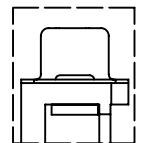

WITH RIVET TYPE

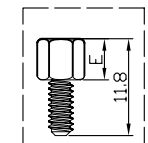

SCREWS

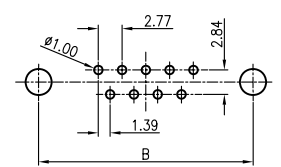
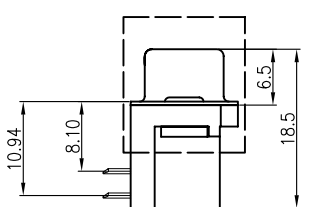
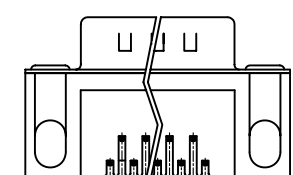

RECOMMEND PCB LAYOUT(TOLERANCE ±0.05)
(VIEW FROM TOP SIDE)

Dimension

Position	A±0.2	B±0.2	C±0.2	D
9	17.90	24.99	30.84	16.33
15	26.50	33.32	39.14	24.66
25	40.00	47.04	53.04	38.38
37	56.50	63.50	69.32	54.84

GENERAL TOLERANCE		ANGLE TOLERANCE	
X.	±0.60	X.	±5°
.X	±0.38	.X	±3°
.XX	±0.25	.XX	±2°
DRAWING TYPE	CUSTOMER		
SCALE	1:1	SHEET	1 OF 1
DRAWING NO.	C-DS1037-03-XXXXXXX		

PROJECTION	TITLE
	D-SUB RIGHT ANGLE(7.2mm) W/O BOARDLOCK TYPE
UNITS	mm
SHEET SIZE	A4
SERIES	DS1037-03 SERIES

晨翔电子有限公司
CONNFLY CONNFLY ELECTRONIC CO. LTD

REV.	DESCRIPTION	DRAWN	CHECKED	APPROVED
A	NEW RELEASE	LJH 06/14/07'	~	LJC 06/14/07'
B	新增螺丝规格	YCH 11/05/11'	~	

NOTES: 备注

- PRODUCTS PERFORMANCE:
 - VOLTAGE RATING: 250V AC.
 - CONTACT CURRENT RATING: 1.5A MAX. PER PIN.
 - CONTACT RESISTANCE: 20mΩ MAX.
 - DIELECTRIC WITHSTANDING VOLTAGE: 500V AC(rms) FOR 1 MINUTE.
 - INSULATION RESISTANCE: 1000MΩ MIN.
 - OPERATING TEMPERATURE: -40°C~+105°C.

2. PRODUCT NUMBER CODE:
DS1037 -01- X X X X X X X X

- SCREW DIM. E
 - 4: 4.80mm
 - 5: 5.80mm
 - ⑥: 4.80mm(Inside thread M2.6*0.45p, outside thread unc#4-40)
 - ⑧: M3: 4.80mm(Inside thread M3.0, outside thread unc#4-40)
- BOARD LOCK DIM. F
 - 4: 4.00mm
 - 7: 3.70mm
- CONTACT PLATING
 - T: SELECTIVE GOLD FLASH
 - Si: FULL GOLD FLASH
 - 6: FULL TIN
- COLOR OF HOUSING
 - K: BLACK
 - B: BLUE
- SCREW TYPE
 - A: WITH SCREW TYPE
 - B: WITH RIVET TYPE
 - C: WITH SCREW AND RIVET TYPE
 - D: RIVET TYPE WITH SCREW IN BULD PACKAGE
- SHELL PLATING
 - N: Nickel
 - T: Tin
- CONNECTOR TYPE
 - M: MALE
 - F: FEMALE
- No. OF CONTACT
 - 09: 9pos.
 - 15: 15pos.
 - 25: 25pos.
 - 37: 37pos.

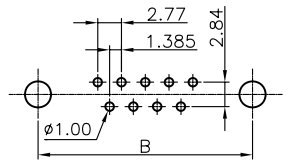
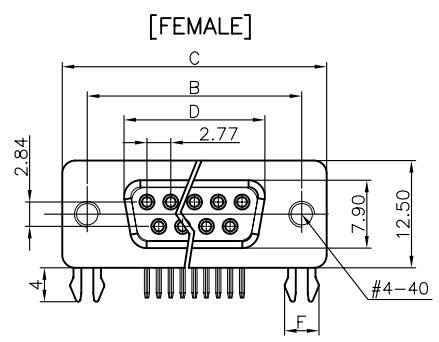

RECOMMEND PCB LAYOUT(TOLERANCE ±0.05)
(VIEW FROM TOP SIDE)

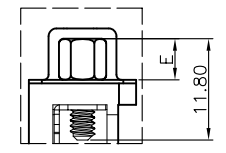
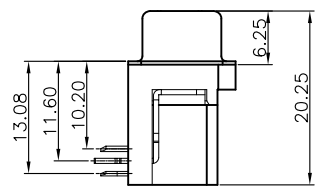
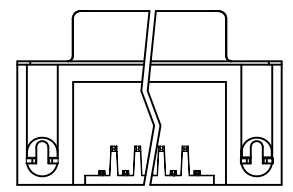

WITH SCREW TYPE

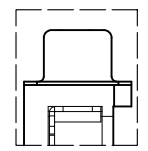
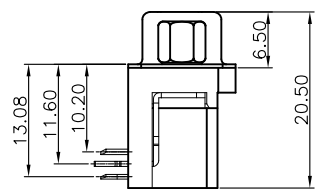
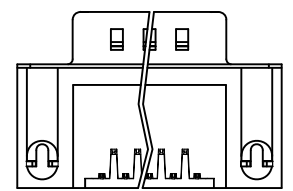
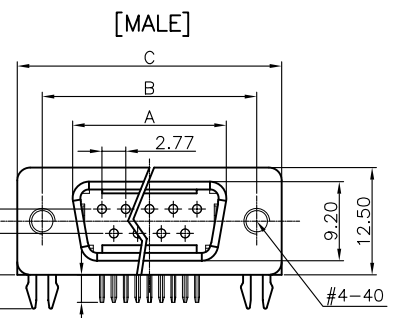

WITH RIVET TYPE

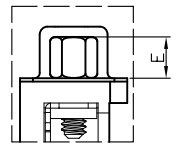

WITH SCREW AND RIVET TYPE

Dimension				
Position	A±0.2	B±0.2	C±0.2	D
9	17.90	24.99	30.80	16.33
15	26.50	33.32	39.14	24.66
25	40.00	47.04	53.04	38.38
37	56.50	63.50	69.32	54.84

GENERAL TOLERANCE		ANGLE TOLERANCE	
X.	±0.50	X.	±3°
.X	±0.30	.X	±2°
.XX	±0.20	.XX	±1°
DRAWING TYPE		ASSEMBLY	
SCALE	1:1	SHEET	1 OF 1
DRAWING NO.	C-DS1037-01-XXXXXXX-B		

PROJECTION	TITLE
	D-SUB RIGHT ANGLE(9.4mm) TYPE
UNITS	mm
SHEET SIZE	A4
SERIES	DS1037-01 SERIES

晨翔电子有限公司
CONNFLY CONNFLY ELECTRONIC CO. LTD