

REV.	DESCRIPTION	DRAWN	CHECKED	APPROVED
A	NEW RELEASE	YCH 05/08/12'	~	

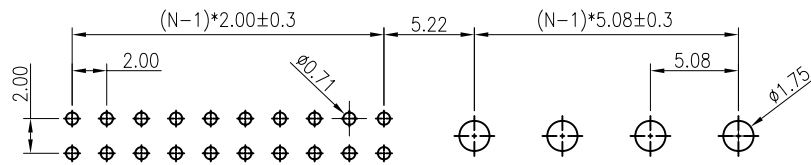
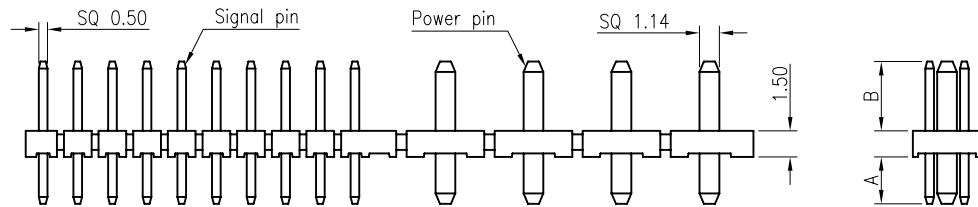
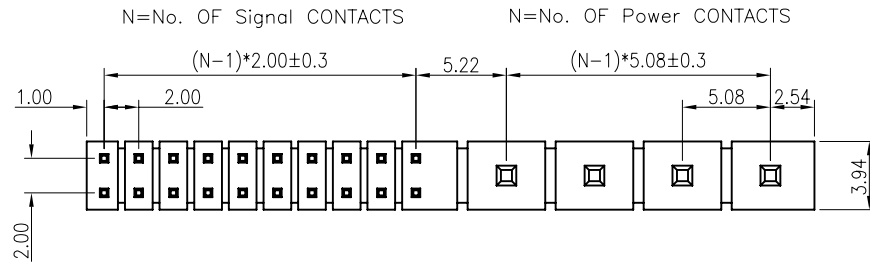

RECOMMEND PCB LAYOUT
(TOLERANCE=±0.05)

NOTES:

- ELECTRICAL CHARACTERISTICS:
 - CONTACT RESISTANCE: 20mΩ Max.
 - DIELECTRIC WITHSTANDING VOLTAGE: 500V AC(rms) FOR 1 MINUTE.
 - INSULATION RESISTANCE: 1000MΩ Min.
- ENVIRONMENT CHARACTERISTICS:
 - OPERATING TEMPERATURE: -40°C~+105°C.
- PRODUCT NUMBER CODE:

DS1021-08- X - X X X X

TABLE A & DIM. TYPE
1: TYPE 1

CONTACT PLATING
F1: FULL GOLD FLASH
6: TIN

MOUNTING TYPE
S: Straight TYPE

No. OF Power CONTACTS
1*1~1*4

No. OF Signal CONTACTS
2*1~2*39

TABLE A:

TYPE	Dimension	
	A	B
1	2.71	4.00
2		
3		
4		
5		
6		
7		
8		
9		
10		

GENERAL TOLERANCE		ANGLE TOLERANCE	
X.	±0.60	X.	±5°
.X	±0.38	.X	±3°
.XX	±0.25	.XX	±2°
DRAWING TYPE	CUSTOMER		
SCALE	~	SHEET	1 OF 2
DRAWING NO.	C-DS1021-08-2*X-1*X-XXX		

PROJECTION	TITLE	PIN HEADER PITCH 5.08mm COMBINATION	
UNITS	mm	PIN HEADER PITCH 2.00mm V/T TYPE	
SHEET SIZE	A4	SERIES	DS1021-08 SERIES



晨翔电子有限公司

CONNFLY CONNFLY ELECTRONIC CO. LTD

REV.	DESCRIPTION	DRAWN	CHECKED	APPROVED
A	NEW RELEASE	YCH 05/08/12'	~	

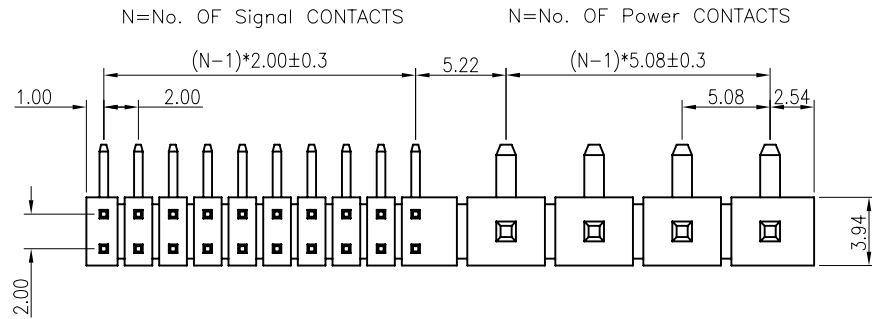

NOTES:

- ELECTRICAL CHARACTERISTICS:
 - CONTACT RESISTANCE: 20mΩ Max.
 - DIELECTRIC WITHSTANDING VOLTAGE: 500V AC(rms) FOR 1 MINUTE.
 - INSULATION RESISTANCE: 1000MΩ Min.
- ENVIRONMENT CHARACTERISTICS:
 - OPERATING TEMPERATURE: -40°C~+105°C.
- PRODUCT NUMBER CODE:

DS1021-09- X - X X X X

TABLE A & DIM. TYPE
1: TYPE 1
...

CONTACT PLATING
F1: FULL GOLD FLASH
6: TIN
MOUNTING TYPE
R: R/A

No. OF Power CONTACTS
1*1~1*4
No. OF Signal CONTACTS
2*1~2*39

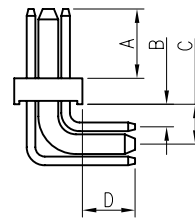
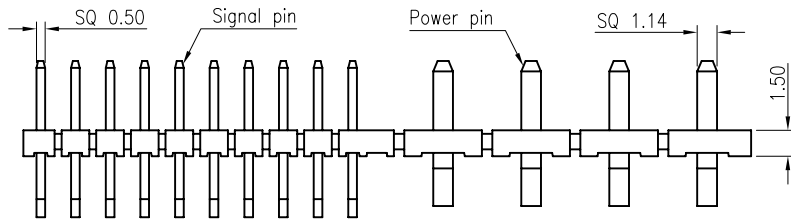
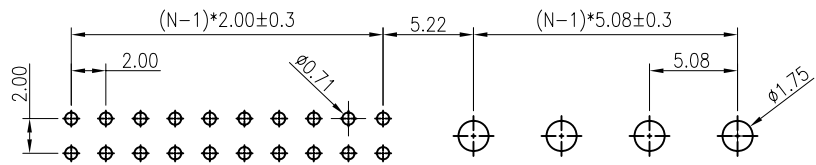

TABLE A:

TYPE	Dimension			
	A	B	C	D
1	4.00	1.27	2.30	3.04
2				
3				
4				
5				
6				
7				
8				
9				
10				



RECOMMEND PCB LAYOUT
(TOLERANCE=±0.05)

GENERAL TOLERANCE		ANGLE TOLERANCE		PROJECTION		TITLE	PIN HEADER PITCH 5.08mm COMBINATION
X.	±0.60	X.	±5°	UNITS	mm		PIN HEADER PITCH 2.00mm R/A TYPE
.X	±0.38	.X	±3°	SHEET SIZE	A4	SERIES	DS1022-18 SERIES
.XX	±0.25	.XX	±2°	晨翔电子有限公司 CONNFLY CONNFLY ELECTRONIC CO. LTD			
DRAWING TYPE		CUSTOMER					
SCALE		SHEET 1 OF 2					
DRAWING NO.		C-DS1022-18-2*X-1*X-XXX					

REV.	DESCRIPTION	DRAWN	CHECKED	APPROVED
A	NEW RELEASE	YCH 05/08/12'	~	

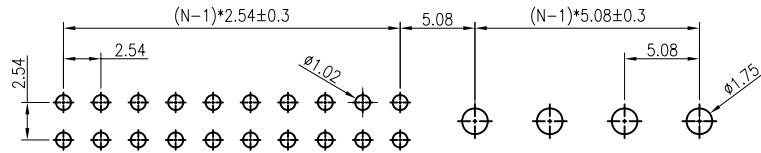
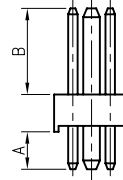
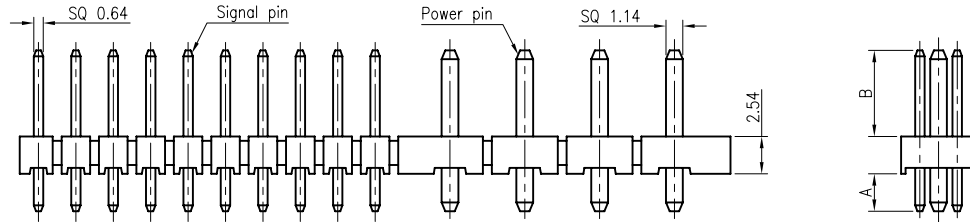
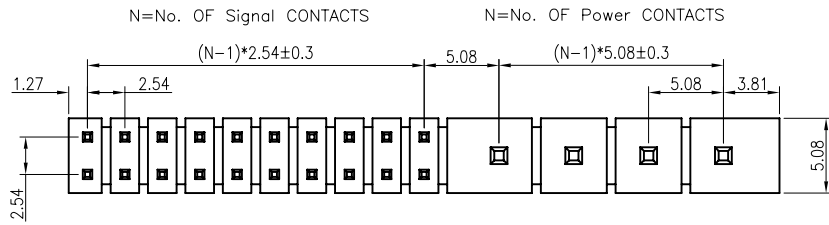

RECOMMEND PCB LAYOUT
(TOLERANCE=±0.05)

NOTES:

- ELECTRICAL CHARACTERISTICS:
 - CONTACT RESISTANCE: 20mΩ Max.
 - DIELECTRIC WITHSTANDING VOLTAGE: 500V AC(rms) FOR 1 MINUTE.
 - INSULATION RESISTANCE: 1000MΩ Min.
- ENVIRONMENT CHARACTERISTICS:
 - OPERATING TEMPERATURE: -40°C~+105°C.
- PRODUCT NUMBER CODE:

DS1021-07- X - X X X X

TABLE A & DIM. TYPE
1: TYPE 1
2: TYPE 2
...

CONTACT PLATING
F1: FULL GOLD FLASH
6: TIN

MOUNTING TYPE
S: Straight TYPE

No. OF Power CONTACTS
1*2~1*4

No. OF Signal CONTACTS
2*2~2*24

TABLE A:

TYPE	Dimension	
	A	B
1	2.54	5.84
2	2.54	8.13
3		
4		
5		
6		
7		
8		
9		
10		

GENERAL TOLERANCE		ANGLE TOLERANCE		PROJECTION		TITLE	PIN HEADER PITCH 5.08mm COMBINATION
X.	±0.60	X.	±5'	UNITS	mm		PIN HEADER PITCH 2.54mm V/T TYPE
.X	±0.38	.X	±3'	SHEET SIZE	A4	SERIES	DS1021-07 SERIES
.XX	±0.25	.XX	±2'	晨翔电子有限公司 CONNFLY CONNFLY ELECTRONIC CO. LTD			
DRAWING TYPE		CUSTOMER					
SCALE		SHEET 1 OF 2					
DRAWING NO.		C-DS1021-07-2*X-1*X-XXX					

REV.	DESCRIPTION	DRAWN	CHECKED	APPROVED
A	NEW RELEASE	YCH 05/08/12'	~	

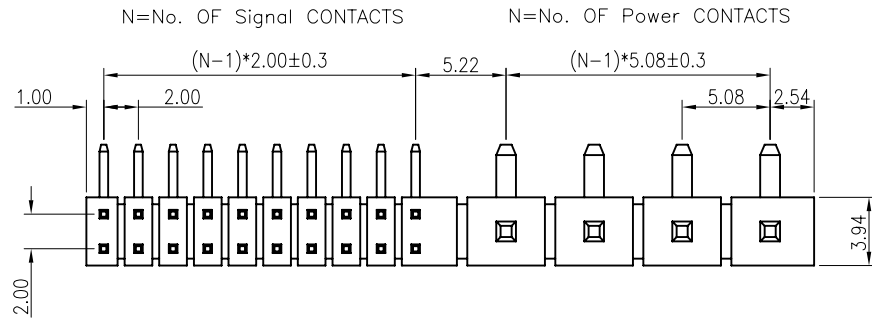

NOTES:

- ELECTRICAL CHARACTERISTICS:
 - CONTACT RESISTANCE: 20mΩ Max.
 - DIELECTRIC WITHSTANDING VOLTAGE: 500V AC(rms) FOR 1 MINUTE.
 - INSULATION RESISTANCE: 1000MΩ Min.
- ENVIRONMENT CHARACTERISTICS:
 - OPERATING TEMPERATURE: -40°C~+105°C.
- PRODUCT NUMBER CODE:

DS1021-09- X - X X X X

TABLE A & DIM. TYPE
1: TYPE 1
...

CONTACT PLATING
F1: FULL GOLD FLASH
6: TIN
MOUNTING TYPE
R: R/A

No. OF Power CONTACTS
1*1~1*4
No. OF Signal CONTACTS
2*1~2*39

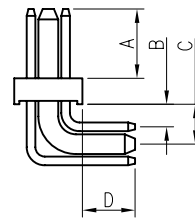
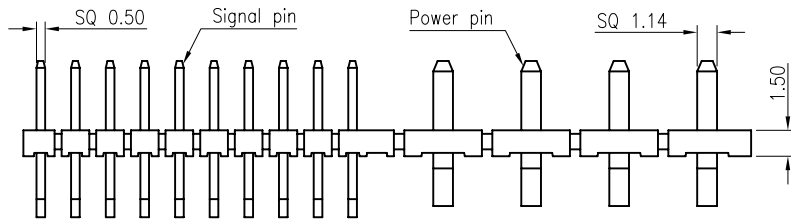
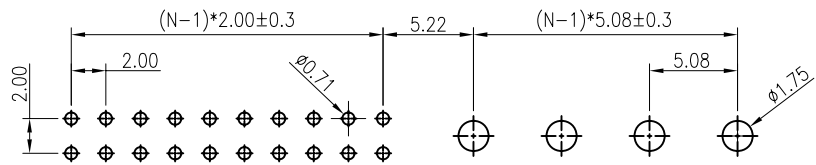

TABLE A:

TYPE	Dimension			
	A	B	C	D
1	4.00	1.27	2.30	3.04
2				
3				
4				
5				
6				
7				
8				
9				
10				



RECOMMEND PCB LAYOUT
(TOLERANCE=±0.05)

GENERAL TOLERANCE		ANGLE TOLERANCE		PROJECTION		TITLE	PIN HEADER PITCH 5.08mm COMBINATION
X.	±0.60	X.	±5°	UNITS	mm		PIN HEADER PITCH 2.00mm R/A TYPE
.X	±0.38	.X	±3°	SHEET SIZE	A4	SERIES	DS1022-18 SERIES
.XX	±0.25	.XX	±2°	晨翔电子有限公司 CONNFLY CONNFLY ELECTRONIC CO. LTD			
DRAWING TYPE		CUSTOMER					
SCALE		SHEET 1 OF 2					
DRAWING NO.		C-DS1022-18-2*X-1*X-XXX					

REV.	DESCRIPTION	DRAWN	CHECKED	APPROVED
A	NEW RELEASE	YCH 05/08/12'	~	

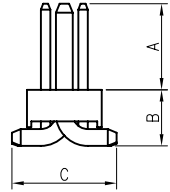
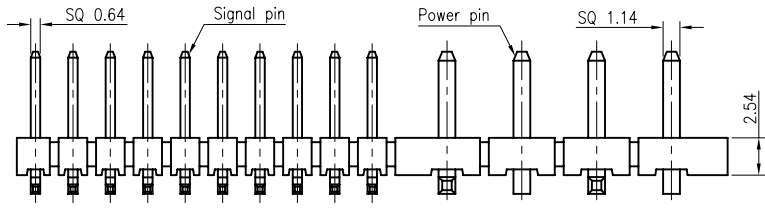
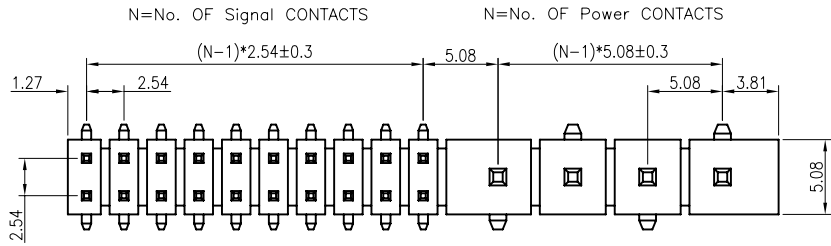

NOTES:

- ELECTRICAL CHARACTERISTICS:
 - CONTACT RESISTANCE: 20mΩ Max.
 - DIELECTRIC WITHSTANDING VOLTAGE: 500V AC(rms) FOR 1 MINUTE.
 - INSULATION RESISTANCE: 1000MΩ Min.
- ENVIRONMENT CHARACTERISTICS:
 - OPERATING TEMPERATURE: -40°C~+105°C.
- PRODUCT NUMBER CODE:

DS1022-17- X - X X X X

TABLE A & DIM. TYPE
 1: TYPE 1
 2: TYPE 2
 ...
 CONTACT PLATING
 F1: FULL GOLD FLASH
 6: TIN
 MOUNTING TYPE
 M: SMT
 No. OF Power CONTACTS
 1*2~1*4
 No. OF Signal CONTACTS
 2*2~2*24

TABLE A:

TYPE	Dimension		
	A	B	C
1	5.84	3.81	7.11
2	8.13	3.81	7.11
3			
4			
5			
6			
7			
8			
9			
10			

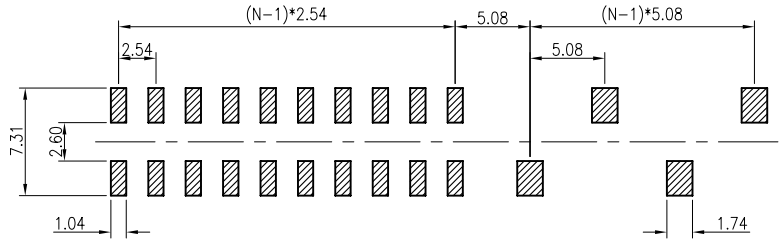

RECOMMEND PCB LAYOUT
(TOLERANCE=±0.05)

GENERAL TOLERANCE		ANGLE TOLERANCE		PROJECTION		TITLE	PIN HEADER PITCH 5.08mm COMBINATION
X.	±0.60	X.	±5°	UNITS	mm		PIN HEADER PITCH 2.54mm SMT TYPE
.X	±0.38	.X	±3°	SHEET SIZE	A4	SERIES	DS1022-17 SERIES
.XX	±0.25	.XX	±2°	晨翔电子有限公司 CONNFLY CONNFLY ELECTRONIC CO. LTD			
DRAWING TYPE		CUSTOMER					
SCALE		SHEET 1 OF 2					
DRAWING NO.		C-DS1022-17-2*X-1*X-XXX					