

REV.	DESCRIPTION	DRAWN	CHECKED	APPROVED
A	NEW RELEASE	YCH 03/24/09	~	

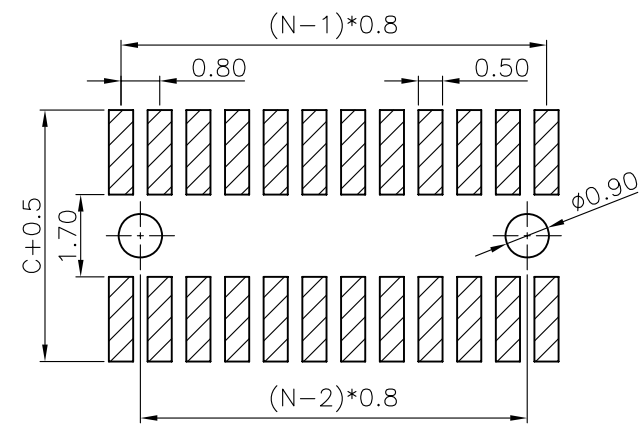
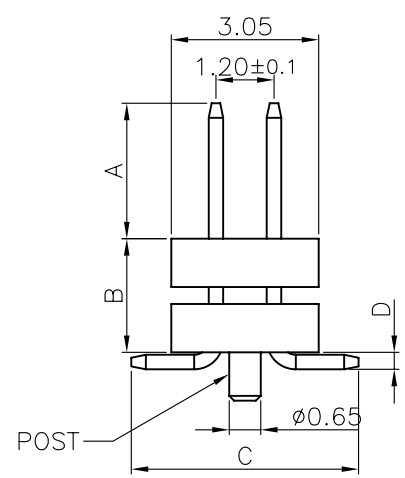
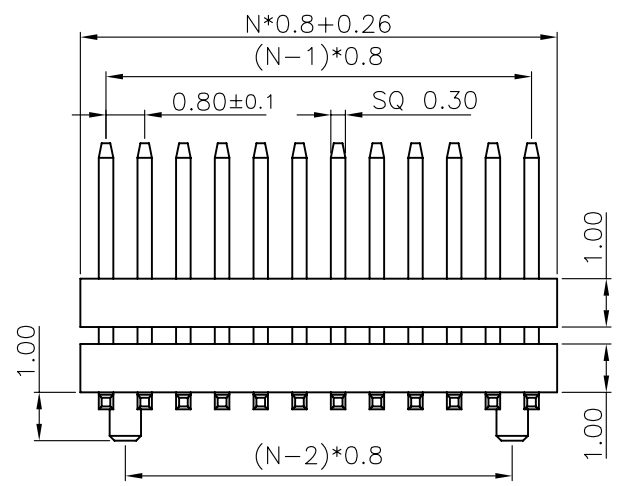
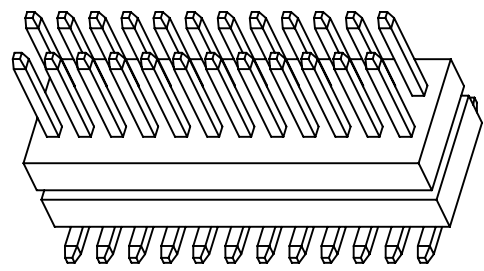
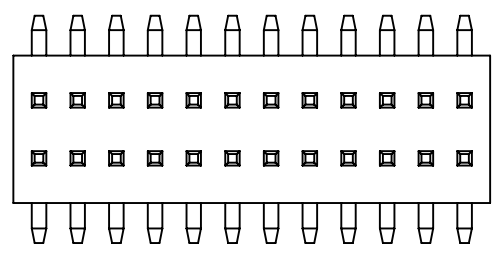

RECOMMEND PCB LAYOUT(TOLERANCE=±0.05)

TYPE	DIM A	DIM B	DIM C	DIM D
1	2.80	2.35	4.70	0.35
2				
3				
4				
5				
6				

NOTES:

- MATERIAL
 - INSULATOR:PA-46(UL 94V-0).
 - CONTACT MATERIAL:COPPER ALLOY.
- SPECIFICATION
 - CURRENT RATING:1.0 Amp.
 - INSULATION RESISTANCE:500MΩ Min.
 - DIELECTRIC WITHSTANDING:600VAC.
 - CONTACT RESISTANCE:20mΩ Max.
 - OPERATING TEMPERATURE:-40°C TO +105°C.
- PART NUMBER: DS1031-29
- PRODUCT NUMBER CODE:

DS1031-29 - X X X X X X X X

- POST SUPPORT
S:W/ POST
X:W/O POST
- PACKING TYPE
T:TRAY
R:TAPE ON REEL
B:TUBE
- PICK UP SUPPORT
S:W/ PICK UP
X:W/O PICK UP
- DIM.A B TYPE
1: TYPE 1
- MOUNTING TYPE
S: SMT TYPE
- HOUSING COLOR
B:BLACK
- CONTACT PLATING
8: FULL GOLD FLASH
- CONNECTOR TYPE
P:PLUG
- No.OF CONTACTS
2*2-2*40

GENERAL TOLERANCE		ANGLE TOLERANCE		PROJECTION		TITLE	DUAL ROW PIN HEADER			
X.	±0.60	X.	±5°	UNITS	mm	PITCH 0.8mm STACK SMT TYPE				
.X	±0.38	.X	±3°	SHEET SIZE	A4	SERIES	DS1031-29 SERIES			
.XX	±0.25	.XX	±2°							
DRAWING TYPE		CUSTOMER				晨翔电子有限公司 CONNFLY CONNFLY ELECTRONIC CO. LTD				
SCALE		1:1		SHEET					1 OF 1	
DRAWING NO.		C-DS1031-29-XXXXXXXXX								