

REV.	DESCRIPTION	DRAWN	CHECKED	APPROVED
A	NEW RELEASE	LJC 03/15/07'	~	LJC 03/15/07'
B	增加料号	LJC 10/25/11'	~	

备注/Notes:

- 1.材料/Material: 铜材/Copeer alloy.
- 2.电镀/Plating: 80~150u"镍/80~150u" Nickel.
- 3.料号说明/Part Number Code:

N - LXXXX - XXXX - XX

螺牙规格/Screw type (DIM C)

03 : M3.0

04 : #4-40

螺母总长 (DIM L Length):

0190:1.90mm

0200:2.00mm

0230:2.30mm

0480:4.80mm

0500:5.00mm

0600:6.00mm

0700:7.00mm

0800:8.00mm

1000:10.00mm

1200:12.00mm

1500:15.00mm

2000:20.00mm

2500:25.00mm

3000:30.00mm

4000:40.00mm

5000:50.00mm

六角面宽度 (DIM B)

0465:4.65mm

0475:4.75mm

0490:4.90mm

0500:5.00mm

0540:5.40mm

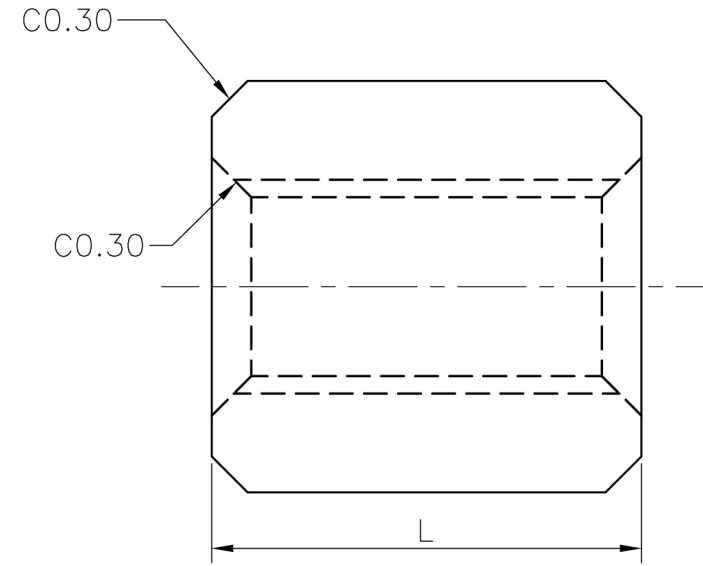
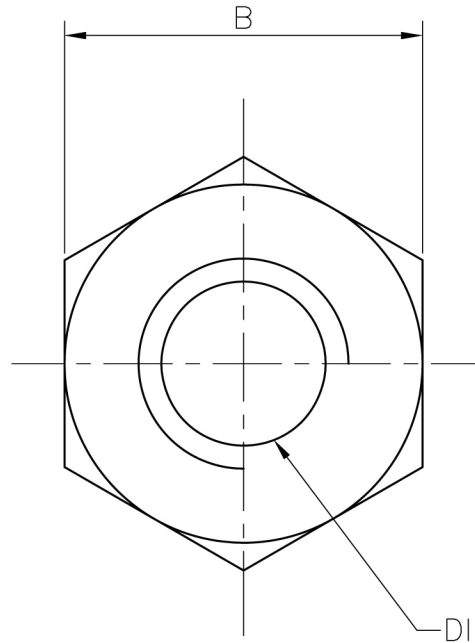

GENERAL TOLERANCE		ANGLE TOLERANCE	
X.	±0.20	X.	±2°
.X	±0.15	.X	±1°
.XX	±0.10	.XX	±0.5°

DRAWING TYPE	COMPONENTS		
SCALE	1:1	SHEET	1 OF 1
DRAWING NO.	N-LXXXX-XXXX-XX-B		

PROJECTION	⊕	TITLE
UNITS	mm	NUT
SHEET SIZE	A4	SERIES NUT SERIES

REV.	DESCRIPTION	DRAWN	CHECKED	APPROVED
A	NEW RELEASE	LJC 06/18/05'		

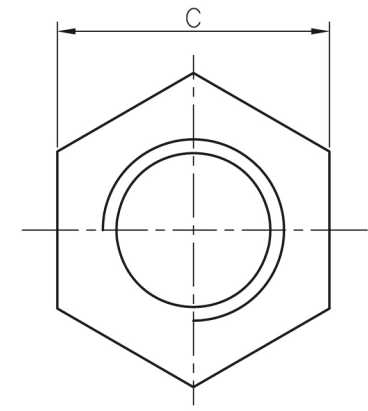
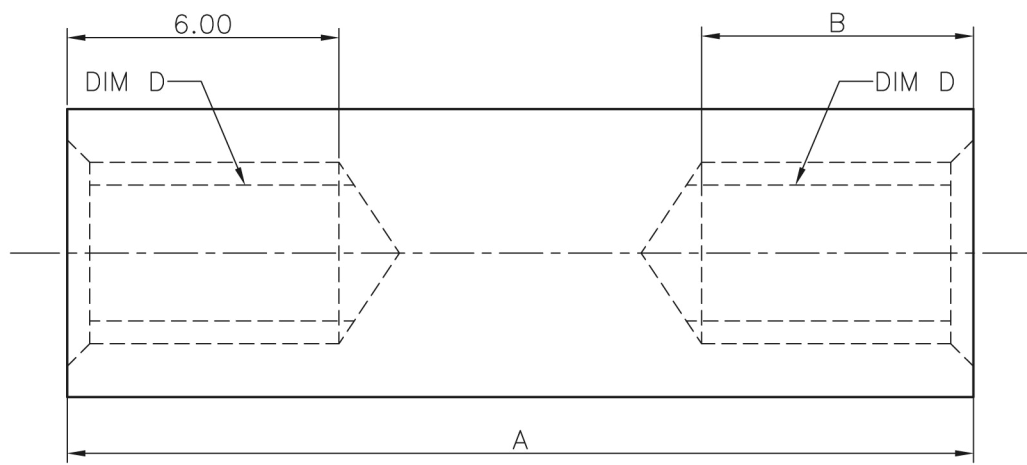

NOTES:

- 1.Materials: Copper alloy.
- 2:Plating: Nickel plating.
- 3:Part number code:
H - LXXXX - XXXX -6 -M4 - 2N

Thread type: DIM D
M4: M4.0

DIM C:
6: 6.0mm

DIM B:
1000: 10mm

DIM A:
1000: 10mm

GENERAL TOLERANCE		ANGLE TOLERANCE		PROJECTION		TITLE	
X.	±0.30	X.	±2°	UNITS	mm	Screws	
.X	±0.20	.X	±1°	SHEET SIZE	A4	SERIES	Hardwares SERIES
.XX	±0.15	.XX	±0.5°				
DRAWING TYPE		CUSTOMER DRAWING					
SCALE	1:1	SHEET	1 OF 1				
DRAWING NO.	H-LXXXX-XXXX-6-4M-2N						