

Power

SERIE BS88

BS88 Series

Série BS88



FUSIBILI BS88 240V EXTRARAPIDI

Ultra-quick BS88 240V fuses | Fusibles BS88 240V ultra rapides



FUSIBILI BS88 690V EXTRARAPIDI

Ultra-quick BS88 690V fuses | Fusibles BS88 690V ultra rapides



ACCESSORI

Accessories | Accessoires



FUSIBILI BS88 INDUSTRIALI

Industrials BS88 fuses | Fusibles industriels BS88



PRODUTTORI | Manufacturers | Producteurs

Bussmann

Power



SERIE BS88

BS88 Series

Série BS88

INFORMAZIONI GENERALI

General Information

Informations Générales

■ IL TEMPO DI INTERVENTO I^2t

Il tempo di intervento I^2t alla tensione nominale e al fattore di potenza del 15% è indicato nelle caratteristiche elettriche. Per altre tensioni il tempo di intervento I^2t si può trovare moltiplicando E_g (RMS) per il fattore di correzione K dato come una funzione della tensione di lavoro applicata.

■ ARCO DI VOLTAGGIO

Questa curva indica il picco dell'arco di voltaggio U_L che dovrebbe apparire attraverso il fusibile mentre lavora come funzione della tensione di lavoro applicata E_g (RMS) al fattore di potenza del 15%.

■ PERDITA DI POTENZA

La perdita di watt alla corrente nominale è indicata nelle caratteristiche elettriche. La curva permette di calcolare le perdite di potenza a carichi di corrente inferiori alla corrente nominale. Il fattore di correzione K_p è dato come funzione del carico di corrente RMS, I_b , in percentuale della corrente nominale.

■ TOTAL CLEARING TIME I^2t

The total clearing I^2t at rated voltage and at power factor of 15% are given in the electrical characteristics. For other voltages, the clearing I^2t is found by multiplying by correction factor, K , given as a function of applied working voltage, E_g , (RMS).

■ ARC VOLTAGE

This curve gives the peak arc voltage, U_L , which may appear across the fuse during its operation as a function of the applied working voltage, E_g , (RMS) at a power factor of 15%.

■ POWER LOSSES

Watts loss at rated current is given in the electrical characteristics. The curve allows the calculation of the power losses at load currents lower than the rated current. The correction factor, K_p , is given as a function of the RMS load current, I_b , in % of the rated current.

■ LE TEMPS D'INTERVENTION I^2t

Le temps d'intervention I^2t à la tension nominale et au facteur de puissance de 15% est indiqué dans les caractéristiques électriques. Pour d'autres tensions, le temps d'intervention I^2t peut être trouvé en multipliant E_g (RMS) par le facteur de correction K donné comme une fonction de la tension courante.

■ L'ARC DE VOLTAGE

Cette courbe indique le pic de l'arc de voltage U_L qui devrait apparaître à travers le fusible pendant qu'il travaille comme une fonction de la tension courante E_g (RMS) à un facteur de puissance de 15%.

■ PERTE DE PUISSANCE

La perte de Watts au courant nominal est indiquée dans les caractéristiques électriques. La courbe permet de calculer la perte de puissance d'un courant en charge inférieur au courant nominal. Le facteur de correction K_p est donné comme fonction de la charge de courant RMS, I_b , en pourcentage du courant nominal.



APPLICAZIONI

Applications | Applications

- **UPS**
UPS system | UPS
- **Muletti**
Lifts | Chariots elevateurs
- **Montacarichi**
Elevators | Monte-charges
- **Export in G.B.**
Export to G.B. | Export en G.B.
- **Protezione di semiconduttori**
Semiconductors protection | Protection de semi-conducteurs

VANTAGGI

Advantages | Avantages

- **Piccole dimensioni**
Small size | Petites tailles
- **Basso costo**
Low cost | Prix bas
- **Bassissimo I²t**
Lowest I²t | Tres bas I²t
- **Ottima performance in D.C.**
Excellent performance under D.C | Performance optimale en D.C.

STRUTTURA DEL CODICE

Code structure | Structure du code

Fusibili BS88 extra rapidi
Ultra-quick BS88 fuses | Fusibles BS88 ultra rapides

BS

Misura
Size | Mesure

LCT

LCT : 47 x 8,7	MT : 113 x 38,1
LET : 56 x 17,7	FE : 77 x 17,1
LMT : 84 x 38,1	FM : 113 x 38,1
LMMT : 84 x 38	FEE : 94 x 37
FC : 74,6 x 8,7	FMM : 113 x 83
ET : 94 x 37	MMT : 113 x 83
EET : 113 x 38,1	

Amperaggio
Amperage | Amperage

002

006 : 6A
010 : 10A
012 : 12A
016 : 16A
etc...



SERIE BS88

BS88 series | Série BS88



FUSIBILI BS88 LCT BS88 LCT fuses | Fusibles BS88 LCT

Caratteristica

Extra rapidi
Corrente
6/20 A
Tensione
240 V / 150 V d.c.
Capacità di rottura
200 kA
Corpo
Ceramica
Contatti
Ottone stagnato
Cod. omologazione
Bussmann LCT
Norme riferimento
BS88.4
IEC 269.4

Characteristic

Ultra-quick
Current
6/20 A
Voltage
240 V / 150 V d.c.
Breaking capacity
200 kA
Body
Ceramic
Contacts
Tinned brass
Approval code
Bussmann LCT
Standards
BS88.4
IEC 269.4

Caractéristique

Ultra rapides
Courant
6/20 A
Tension
240 V / 150 V d.c.
Pouvoir de coupure
200 kA
Corps
Céramique
Contacts
Laiton étamé
Code d'homologation
Bussmann LCT
Normes
BS88.4
IEC 269.4

pag. 155



Codice Code Code	Corrente nominale Rated current Courant nominal	I ² t I ² t Ft	Pot. dissipata Power loss Puiss. dissipée
BS LCT 006	6 A	9	1
BS LCT 010	10 A	22	2,5
BS LCT 012	12 A	32	2,5
BS LCT 016	16 A	100	2,5
BS LCT 020	20 A	160	4

Dimensioni | Dimensions | Dimensions

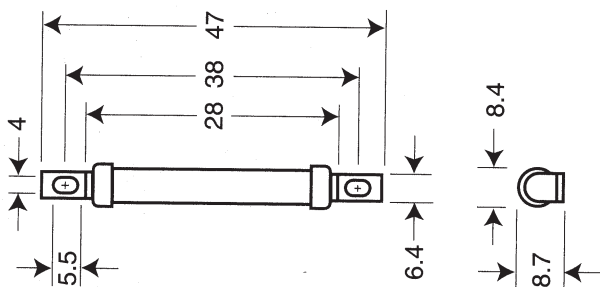

20 pz
20 pcs
20 pces



30 giorni
30 days
30 jours



FUSIBILI BS88 LET BS88 LET fuses | Fusibles BS88 LET

Caratteristica

Extra rapidi
Corrente
25/180 A
Tensione
240 V / 150 V d.c.
Capacità di rottura
200 kA
Corpo
Ceramica
Contatti
Ottone stagnato
Cod. omologazione
Bussmann LET
Norme riferimento
BS88.4
IEC 269.4

Characteristic

Ultra-quick
Current
25/180 A
Voltage
240 V / 150 V d.c.
Breaking capacity
200 kA
Body
Ceramic
Contacts
Tinned brass
Approval code
Bussmann LET
Standards
BS88.4
IEC 269.4

Caractéristique

Ultra rapides
Courant
25/180 A
Tension
240 V / 150 V d.c.
Pouvoir de coupure
200 kA
Corps
Céramique
Contacts
Laiton étamé
Code d'homologation
Bussmann LET
Normes
BS88.4
IEC 269.4

pag. 155



Codice Code Code	Corrente nominale Rated current Courant nominal	I ² t I ² t Ft	Pot. dissipata Power loss Puiss. dissipée
BS LET 025	25 A	250	4
BS LET 032	32 A	450	5
BS LET 035	35 A	600	5
BS LET 050	50 A	1400	7
BS LET 063	63 A	2200	9
BS LET 080	80 A	3800	10
BS LET 100	100 A	7500	10
BS LET 125	125 A	7500	16
BS LET 160	160 A	16000	20
BS LET 180	180 A	29000	21

Dimensioni | Dimensions | Dimensions

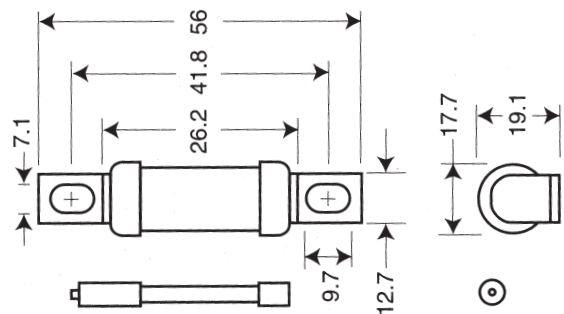

10 pz
10 pcs
10 pces



30 giorni
30 days
30 jours

SERIE BS88

BS88 series | Série BS88

FUSIBILI BS88 LMT
 BS88 LMT fuses | Fusibles BS88 LMT

Caratteristica

Extra rapidi
Corrente
 160/450 A
Tensione
 240 V / 150 V d.c.
Capacità di rottura
 200 kA
Corpo
 Ceramica
Contatti
 Ottone stagnato
Cod. omologazione
 Bussmann LMT
Norme riferimento
 BS88.4
 IEC 269.4

Characteristic

Ultra-quick
Current
 160/450 A
Voltage
 240 V / 150 V d.c.
Breaking capacity
 200 kA
Body
 Ceramic
Contacts
 Tinned brass
Approval code
 Bussmann LMT
Standards
 BS88.4
 IEC 269.4

Caractéristique

Ultra rapides
Courant
 160/450 A
Tension
 240 V / 150 V d.c.
Pouvoir de coupure
 200 kA
Corps
 Céramique
Contacts
 Laiton étamé
Code d'homologation
 Bussmann LMT
Normes
 BS88.4
 IEC 269.4



pag. 155

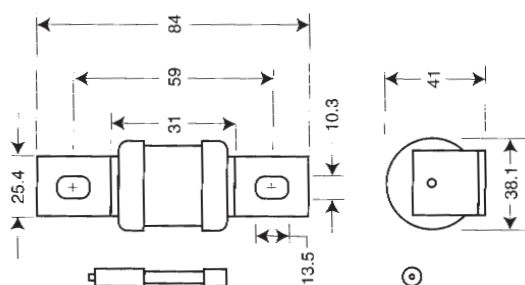

Code Code Code	Corrente nominale Rated current Courant nominal	I ² t I ² t Ft	Pot. dissipata Power loss Puiss. dissipée
BS LMT 160	160 A	16000	17
BS LMT 200	200 A	20000	28
BS LMT 250	250 A	40000	28
BS LMT 315	315 A	75000	35
BS LMT 355	355 A	100000	35
BS LMT 400	400 A	160000	40
BS LMT 450	450 A	220000	42

Dimensioni | Dimensions | Dimensions

 1 pz
 1 pc
 1 pce

 30 giorni
 30 days
 30 jours

FUSIBILI BS88 LMMT
 BS88 LMMT fuses | Fusibles BS88 LMMT

Caratteristica

Extra rapidi
Corrente
 400/900 A
Tensione
 240 V / 150 V d.c.
Capacità di rottura
 200 kA
Corpo
 Ceramica
Contatti
 Ottone stagnato
Cod. omologazione
 Bussmann LMMT
Norme riferimento
 BS88.4
 IEC 269.4

Characteristic

Ultra-quick
Current
 400/900 A
Voltage
 240 V / 150 V d.c.
Breaking capacity
 200 kA
Body
 Ceramic
Contacts
 Tinned brass
Approval code
 Bussmann LMMT
Standards
 BS88.4
 IEC 269.4

Caractéristique

Ultra rapides
Courant
 400/900 A
Tension
 240 V / 150 V d.c.
Pouvoir de coupure
 200 kA
Corps
 Céramique
Contacts
 Laiton étamé
Code d'homologation
 Bussmann LMMT
Normes
 BS88.4
 IEC 269.4



pag. 155

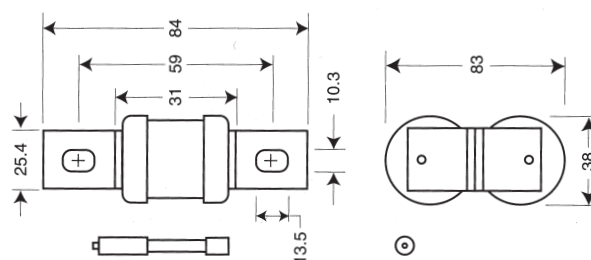

Code Code Code	Corrente nominale Rated current Courant nominal	I ² t I ² t Ft	Pot. dissipata Power loss Puiss. dissipée
BS LMMT 400	400 A	80000	60
BS LMMT 500	500 A	170000	64
BS LMMT 630	630 A	300000	75
BS LMMT 710	710 A	460000	77
BS LMMT 800	800 A	600000	82
BS LMMT 900	900 A	800000	97

Dimensioni | Dimensions | Dimensions

 1 pz
 1 pc
 1 pce

 30 giorni
 30 days
 30 jours

SERIE BS88

BS88 series | Série BS88



FUSIBILI BS88 CT BS88 CT fuses | Fusibles BS88 CT

Caratteristica

Extra rapidi
Corrente
6/20 A
Tensione
690 V/350 V d.c.
Capacità di rottura
200 kA
Corpo
Ceramica
Contatti
Ottone stagnato
Cod. omologazione
Bussmann CT
Norme riferimento
BS88.4
IEC 269.4

Characteristic

Ultra-quick
Current
6/20 A
Voltage
690 V/350 V d.c.
Breaking capacity
200 kA
Body
Ceramic
Contacts
Tinned brass
Approval code
Bussmann CT
Standards
BS88.4
IEC 269.4

Caractéristique

Ultra rapides
Courant
6/20 A
Tension
690 V/350 V d.c.
Pouvoir de coupure
200 kA
Corps
Céramique
Contacts
Laiton étamé
Code d'homologation
Bussmann CT
Normes
BS88.4
IEC 269.4

pag. 156



Codice Code Code	Corrente nominale Rated current Courant nominal	I ² t I ² t Ft	Pot. dissipata Power loss Puiss. dissipée
BS CT 006	6 A	12	2
BS CT 010	10 A	48	3
BS CT 012	12 A	65	3
BS CT 016	16 A	110	7
BS CT 020	20 A	220	7

Dimensioni | Dimensions | Dimensions

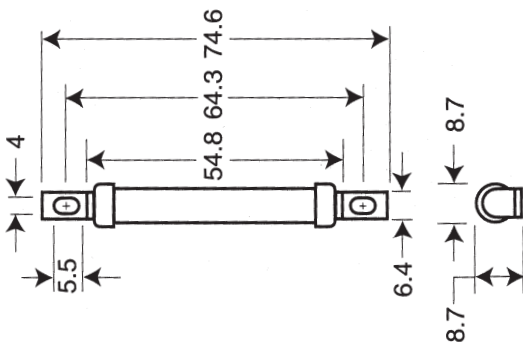

20 pz
20 pcs
20 pces



30 giorni
30 days
30 jours



FUSIBILI BS88 ET BS88 ET fuses | Fusibles BS88 ET

Caratteristica

Extra rapidi
Corrente
25/80 A
Tensione
690 V/350 V d.c.
Capacità di rottura
200 kA
Corpo
Ceramica
Contatti
Ottone stagnato
Cod. omologazione
Bussmann ET
Norme riferimento
BS88.4
IEC 269.4

Characteristic

Ultra-quick
Current
25/80 A
Voltage
690 V/350 V d.c.
Breaking capacity
200 kA
Body
Ceramic
Contacts
Tinned brass
Approval code
Bussmann ET
Standards
BS88.4
IEC 269.4

Caractéristique

Ultra rapides
Courant
25/80 A
Tension
690 V/350 V d.c.
Pouvoir de coupure
200 kA
Corps
Céramique
Contacts
Laiton étamé
Code d'homologation
Bussmann ET
Normes
BS88.4
IEC 269.4

pag. 156



Codice Code Code	Corrente nominale Rated current Courant nominal	I ² t I ² t Ft	Pot. dissipata Power loss Puiss. dissipée
BS ET 025	25 A	250	7
BS ET 032	32 A	350	11
BS ET 035	35 A	500	11
BS ET 040	40 A	900	9
BS ET 045	45 A	1100	11
BS ET 056	56 A	1500	14
BS ET 063	63 A	2000	16
BS ET 080	80 A	4000	18

Dimensioni | Dimensions | Dimensions

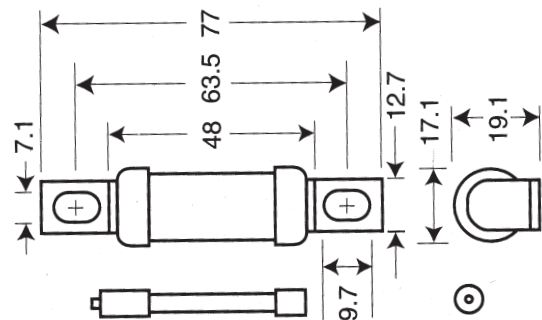

10 pz
10 pcs
10 pces



30 giorni
30 days
30 jours

SERIE BS88
BS88 series | Série BS88



FUSIBILI BS88 EET
BS88 EET fuses | Fusibles BS88 EET

Caratteristica

Extra rapidi
Corrente
90/160 A
Tensione
690 V/350 V d.c.
Capacità di rottura
200 kA
Corpo
Ceramica
Contatti
Ottone stagnato
Cod. omologazione
Bussmann EET
Norme riferimento
BS88.4
IEC 269.4

Characteristic

Ultra-quick
Current
90/160 A
Voltage
690 V/350 V d.c.
Breaking capacity
200 kA
Body
Ceramic
Contacts
Tinned brass
Approval code
Bussmann EET
Standards
BS88.4
IEC 269.4

Caractéristique

Ultra rapides
Courant
90/160 A
Tension
690 V/350 V d.c.
Pouvoir de coupure
200 kA
Corps
Céramique
Contacts
Laiton étamé
Code d'homologation
Bussmann EET
Normes
BS88.4
IEC 269.4

pag. 156



Codice Code Code	Corrente nominale Rated current Courant nominal	I ² t I ² t I ² t	Pot. dissipata Power loss Puiss. dissipée
BS EET 090	90 A	4500	19
BS EET 110	110 A	6500	27
BS EET 140	140 A	12000	35
BS EET 160	160 A	17000	39

Dimensioni | Dimensions | Dimensions

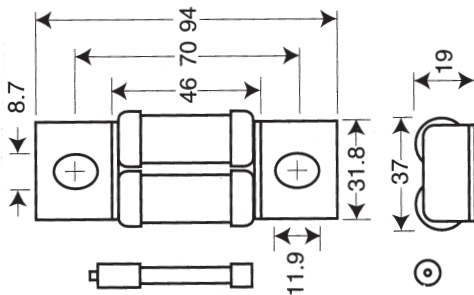

5 pz
5 pcs
5 pces



30 giorni
30 days
30 jours



FUSIBILI BS88 MT
BS88 MT fuses | Fusibles BS88 MT

Caratteristica

Extra rapidi
Corrente
160/355 A
Tensione
690 V/350 V d.c.
Capacità di rottura
200 kA
Corpo
Ceramica
Contatti
Ottone stagnato
Cod. omologazione
Bussmann MT
Norme riferimento
BS88.4
IEC 269.4

Characteristic

Ultra-quick
Current
160/355 A
Voltage
690 V/350 V d.c.
Breaking capacity
200 kA
Body
Ceramic
Contacts
Tinned brass
Approval code
Bussmann MT
Standards
BS88.4
IEC 269.4

Caractéristique

Ultra rapides
Courant
160/355 A
Tension
690 V/350 V d.c.
Pouvoir de coupure
200 kA
Corps
Céramique
Contacts
Laiton étamé
Code d'homologation
Bussmann MT
Normes
BS88.4
IEC 269.4

pag. 156



Codice Code Code	Corrente nominale Rated current Courant nominal	I ² t I ² t I ² t	Pot. dissipata Power loss Puiss. dissipée
BS MT 160	160 A	25000	26
BS MT 180	180 A	38000	26
BS MT 200	200 A	58000	27
BS MT 250	250 A	110000	32
BS MT 280	280 A	150000	35
BS MT 315	315 A	180000	42
BS MT 355	355 A	200000	51

Dimensioni | Dimensions | Dimensions

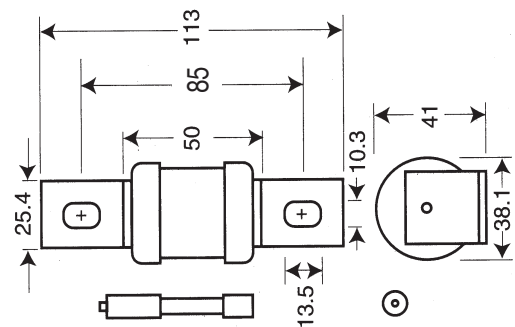

1 pz
1 pc
1 pce

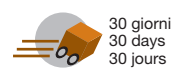

30 giorni
30 days
30 jours

SERIE BS88

BS88 series | Série BS88



FUSIBILI BS88 FE BS88 FE fuses | Fusibles BS88 FE

Caratteristica

Extra rapidi
Corrente
35/100 A
Tensione
690 V/350 V d.c.
Capacità di rottura
200 kA
Corpo
Ceramica
Contatti
Ottone stagnato
Cod. omologazione
Bussmann FE
Norme riferimento
BS88.4
IEC 269.4

Characteristic

Ultra-quick
Current
35/100 A
Voltage
690 V/350 V d.c.
Breaking capacity
200 kA
Body
Ceramic
Contacts
Tinned brass
Approval code
Bussmann FE
Standards
BS88.4
IEC 269.4

Caractéristique

Ultra rapides
Courant
35/100 A
Tension
690 V/350 V d.c.
Pouvoir de coupure
200 kA
Corps
Céramique
Contacts
Laiton étamé
Code d'homologation
Bussmann FE
Normes
BS88.4
IEC 269.4

pag. 157



Codice Code Code	Corrente nominale Rated current Courant nominal	I ² t I ² t Ft	Pot. dissipata Power loss Puiss. dissipée
BS FE 035	35 A	200	9
BS FE 040	40 A	300	9
BS FE 045	45 A	450	11
BS FE 050	50 A	600	11
BS FE 063	63 A	750	12
BS FE 071	71 A	950	17
BS FE 080	80 A	1500	20
BS FE 090	90 A	2100	20
BS FE 100	100 A	2800	23

Dimensioni | Dimensions | Dimensions

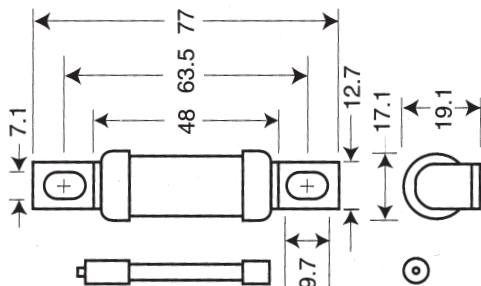

10 pz
10 pcs
10 pces

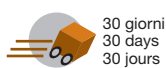

30 giorni
30 days
30 jours

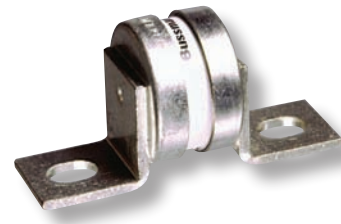

FUSIBILI BS88 FM BS88 FM fuses | Fusibles BS88 FM

Caratteristica

Extra rapidi
Corrente
180/350 A
Tensione
690 V/350 V d.c.
Capacità di rottura
200 kA
Corpo
Ceramica
Contatti
Ottone stagnato
Cod. omologazione
Bussmann FM
Norme riferimento
BS88.4
IEC 269.4

Characteristic

Ultra-quick
Current
180/350 A
Voltage
690 V/350 V d.c.
Breaking capacity
200 kA
Body
Ceramic
Contacts
Tinned brass
Approval code
Bussmann FM
Standards
BS88.4
IEC 269.4

Caractéristique

Ultra rapides
Courant
180/350 A
Tension
690 V/350 V d.c.
Pouvoir de coupure
200 kA
Corps
Céramique
Contacts
Laiton étamé
Code d'homologation
Bussmann FM
Normes
BS88.4
IEC 269.4

pag. 157



Codice Code Code	Corrente nominale Rated current Courant nominal	I ² t I ² t Ft	Pot. dissipata Power loss Puiss. dissipée
BS FM 180	180	13500	40
BS FM 200	200	18500	40
BS FM 225	225	26500	44
BS FM 250	250	37500	48
BS FM 280	280	55000	48
BS FM 315	315	77000	55
BS FM 350	350	105000	55

Dimensioni | Dimensions | Dimensions

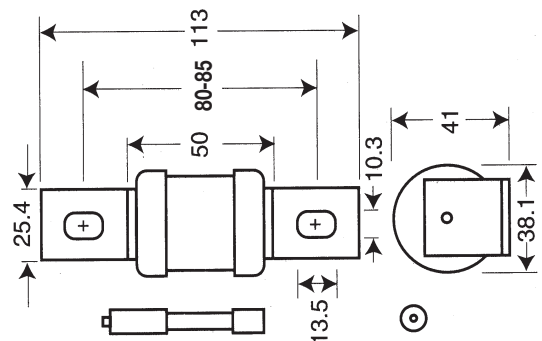

1 pz
1 pc
1 pce



30 giorni
30 days
30 jours

SERIE BS88

BS88 series | Série BS88

FUSIBILI BS88 FEE
 BS88 FEE fuses | Fusibles BS88 FEE

Caratteristica

Extra rapidi
Corrente
 100/200 A
Tensione
 690 V/350 V d.c.
Capacità di rottura
 200 kA
Corpo
 Ceramica
Contatti
 Ottone stagnato
Cod. omologazione
 Bussmann FEE
Norme riferimento
 BS88.4
 IEC 269.4

Characteristic

Ultra-quick
Current
 100/200 A
Voltage
 690 V/350 V d.c.
Breaking capacity
 200 kA
Body
 Ceramic
Contacts
 Tinned brass
Approval code
 Bussmann FEE
Standards
 BS88.4
 IEC 269.4

Caractéristique

Ultra rapides
Courant
 100/200 A
Tension
 690 V/350 V d.c.
Pouvoir de coupure
 200 kA
Corps
 Céramique
Contacts
 Laiton étamé
Code d'homologation
 Bussmann FEE
Normes
 BS88.4
 IEC 269.4



pag. 157

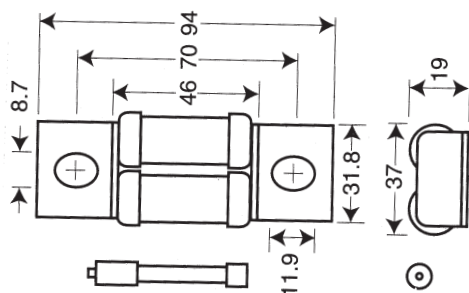

Codice Code Code	Corrente nominale Rated current Courant nominal	I ² t I ² t Ft	Pot. dissipata Power loss Puiss. dissipée
BS FEE 100	100 A	2400	24
BS FEE 120	120 A	3100	32
BS FEE 140	140 A	3800	36
BS FEE 160	160 A	5700	46
BS FEE 180	180 A	8400	46
BS FEE 200	200 A	11400	52

Dimensioni | Dimensions | Dimensions

 5 pz
 5 pcs
 5 pces

 30 giorni
 30 days
 30 jours

FUSIBILI BS88 FMM
 BS88 FMM fuses | Fusibles BS88 FMM

Caratteristica

Extra rapidi
Corrente
 400/700 A
Tensione
 690 V/350 V d.c.
Capacità di rottura
 200 kA
Corpo
 Ceramica
Contatti
 Ottone stagnato
Cod. omologazione
 Bussmann FMM
Norme riferimento
 BS88.4
 IEC 269.4

Characteristic

Ultra-quick
Current
 400/700 A
Voltage
 690 V/350 V d.c.
Breaking capacity
 200 kA
Body
 Ceramic
Contacts
 Tinned brass
Approval code
 Bussmann FMM
Standards
 BS88.4
 IEC 269.4

Caractéristique

Ultra rapides
Courant
 400/700 A
Tension
 690 V/350 V d.c.
Pouvoir de coupure
 200 kA
Corps
 Céramique
Contacts
 Laiton étamé
Code d'homologation
 Bussmann FMM
Normes
 BS88.4
 IEC 269.4



pag. 157

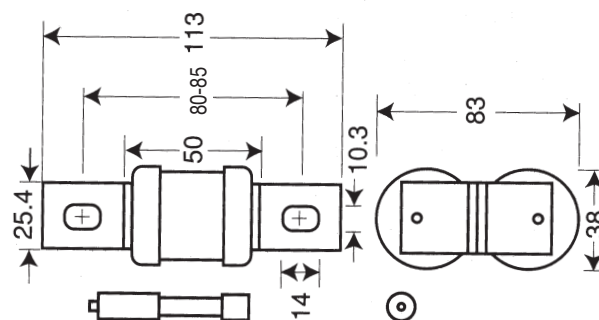

Codice Code Code	Corrente nominale Rated current Courant nominal	I ² t I ² t Ft	Pot. dissipata Power loss Puiss. dissipée
BS FMM 400	400 A	72500	85
BS FMM 450	450 A	105000	90
BS FMM 500	500 A	150000	100
BS FMM 550	550 A	215000	100
BS FMM 630	630 A	310000	100
BS FMM 700	700 A	420000	120

Dimensioni | Dimensions | Dimensions

 1 pz
 1 pc
 1 pce

 30 giorni
 30 days
 30 jours

SERIE BS88

BS88 series | Série BS88



FUSIBILI BS88 MMT BS88 MMT fuses | Fusibles BS88 MMT

Caratteristica

Extra rapidi
Corrente
180/710 A
Tensione
690 V/350 V d.c.
Capacità di rottura
200 kA
Corpo
Ceramica
Contatti
Ottone stagnato
Cod. omologazione
Bussmann MMT
Norme riferimento
BS88.4
IEC 269.4

Characteristic

Ultra-quick
Current
180/710 A
Voltage
690 V/350 V d.c.
Breaking capacity
200 kA
Body
Ceramic
Contacts
Tinned brass
Approval code
Bussmann MMT
Standards
BS88.4
IEC 269.4

Caractéristique

Ultra rapides
Courant
180/710 A
Tension
690 V/350 V d.c.
Pouvoir de coupure
200 kA
Corps
Céramique
Contacts
Laiton étamé
Code d'homologation
Bussmann MMT
Normes
BS88.4
IEC 269.4

pag. 157



Code Code Code	Corrente nominale Rated current Courant nominal	I ² t I ² t I ² t	Pot. dissipata Power loss Puiss. dissipée
BSMMT180	180 A	18000	42
BSMMT200	200 A	23000	42
BSMMT225	225 A	40000	42
BSMMT280	280 A	70000	47
BSMMT315	315 A	91000	51
BSMMT355	355 A	140000	54
BSMMT400	400 A	220000	60
BSMMT450	450 A	320000	57
BSMMT500	500 A	450000	64
BSMMT560	560 A	640000	64
BSMMT630	630 A	720000	86
BSMMT710	710 A	850000	105

Dimensioni | Dimensions | Dimensions

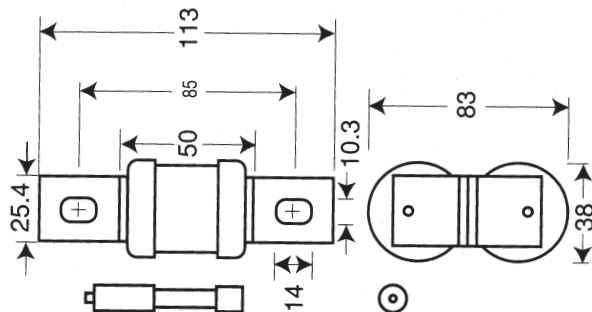

ACCESSORI SERIE BS88 EXTRARAPIDI Ultra-quick BS88 series accessories | Accessoires séries BS88 ultra rapides



Code Code Code	Dimensione Dimension Dimension	Corrente/Tensione Current/Voltage Courant/Tension
Basi e supporti portafusibile Fuse base and Modular Fuseblocks Bases et Supports à blocs		
BSC5268-4	Base portafusibile / Fuse base / Bases porte-fusible	100 A 690 V NEW
BSC5268-1	Base portafusibile / Fuse base / Bases porte-fusible	200 A 690 V NEW
• ULBH1133	Supporti a blocchi / Modular fuseblocks / Supports à blocs	400 A 2500 V NEW
• ULBH3145	Supporti a blocchi / Modular fuseblocks / Supports à blocs	700 A 1250 V NEW
Indicatore di fusione (1) Trip indicator Indicateurs de fusion		
BSTI250	37,6 mm	250 V
BSTI500	47,5 mm	500 V
BSTI600	55,7 mm	600 V
BSTI700	61,8 mm	700 V
BSTI1100	98,4 mm	1100 V
BSTI1500	120,8 mm	1500 V
BSTI2000	147,5 mm	2000 V
BSTI2500	198,3 mm	2500 V
Fascette di fissaggio (2) Fuse clips Clips de fixation		
BSCL1	clip universale/universal clip/clip universel	
BSE	da utilizzare con/to use with/à utiliser avec ET - LET - EET - FE - FEE	
BSM	da utilizzare con/to use with/à utiliser avec FMM - FM - LMT - LMM	
Microswitch e adattatore (3) Microswitch and adaptor Microswitch et adaptateur		
BS1ZN	micro/micro/micro	
BSMAI	contatti a saldare/solder contact/contacts à souder	
BSMBI	contatti a saldare 90°/90° solder contact/contacts à souder 90°	
BS1ZNS	supporto per micro/support for micro/support pour micro	



• Supporti omologati UR e CSA fino a 700V
Modular fuseblocks approved UR and CSA up to 700V
Supports à blocs homologues US et CSA jusqu'à 700V



SERIE BS88

BS88 series | Série BS88

FUSIBILI BS88 INDUSTRIALI NITD

NITD Industrials BS88 Fuses | Fusibles Industriels BS88 NITD

Caratteristica	Characteristic	Caractéristique
Rapidi	Fast	Rapides
Corrente 2A/32A	Current 2A/32A	Courant 2A/32A
Tensione 550 V	Voltage 550 V	Tension 550 V
Capacità di rottura 80 kA	Breaking capacity 80 kA	Pouvoir de coupure 80 kA
Corpo Ceramica	Body Ceramic	Corps Céramique
Cod. omologazione Bussmann: NITD (A1)	Approval code Bussmann: NITD (A1)	Code d'homologation Bussmann: NITD (A1)
Norme riferimento BS88.1 IEC 60269-1	Standards BS88.1 IEC 60269-1	Normes BS88.1 IEC 60269-1

pag. 158



Codice	Corrente nominale	I ² t	Pot. dissipata
Code	Rated current	I ² t	Power loss
Code	Courant nominal	Ft	Puiss. dissipée
BSNITD002	2 A	5	0,9
BSNITD004	4 A	30	1,4
BSNITD006	6 A	115	1,8
BSNITD010	10 A	490	2,1
BSNITD016	16 A	730	1,8
BSNITD020	20 A	1700	1,8
BSNITD025	25 A	3550	2,0
BSNITD032	32 A	5000	2,9

BASE PORTAFUSIBILE
 Fuse base | Base porte-fusibles

Codice	Descrizione	Corrente nominale	Tensione
Code	Description	Rated current	Voltage
Code	Description	Courant nominal	Tension
BSCM32FC	Base portafusibile/Fuse base/Base porte-fusibles	32 A	660 V

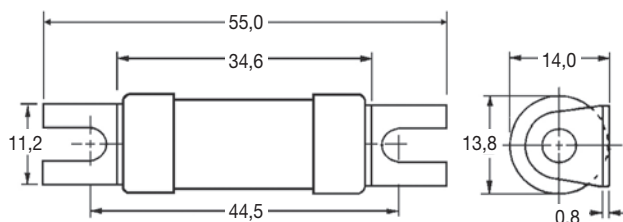
Dimensioni | Dimensions | Dimensions

20 pz / 20 pcs / 20 pces
 pronta in stock / en stock
 su richiesta fornibile versione per motore / motor version upon request / version pour moteur fournissable sur demande

FUSIBILI BS88 INDUSTRIALI AAO

AAO Industrials BS88 Fuses | Fusibles Industriels BS88 AAO

Caratteristica	Characteristic	Caractéristique
Rapidi	Fast	Rapides
Corrente 2A/32A	Current 2A/32A	Courant 2A/32A
Tensione 550 V	Voltage 550 V	Tension 550 V
Capacità di rottura 80 kA	Breaking capacity 80 kA	Pouvoir de coupure 80 kA
Corpo Ceramica	Body Ceramic	Corps Céramique
Cod. omologazione Bussmann: AAO (A2)	Approval code Bussmann: AAO (A2)	Code d'homologation Bussmann: AAO (A2)
Norme riferimento BS88.1 IEC 60269-1	Standards BS88.1 IEC 60269-1	Normes BS88.1 IEC 60269-1

pag. 158



Codice	Corrente nominale	I ² t	Pot. dissipata
Code	Rated current	I ² t	Power loss
Code	Courant nominal	Ft	Puiss. dissipée
BSAA0002	2 A	5	0,9
BSAA0004	4 A	30	1,4
BSAA0006	6 A	115	1,8
BSAA0010	10 A	500	2,1
BSAA0016	16 A	750	1,8
BSAA0020	20 A	1700	1,8
BSAA0025	25 A	2500	2,0
BSAA0032	32 A	5000	2,9

BASE PORTAFUSIBILE
 Fuse base | Base porte-fusibles

Codice	Descrizione	Corrente nominale	Tensione
Code	Description	Rated current	Voltage
Code	Description	Courant nominal	Tension
BSCM32F	Base portafusibile/Fuse base/Base porte-fusibles	32 A	660 V

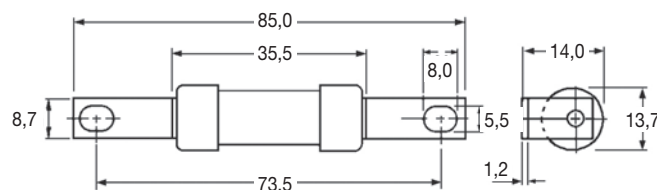
Dimensioni | Dimensions | Dimensions

20 pz / 20 pcs / 20 pces
 pronta in stock / en stock
 su richiesta fornibile versione per motore / motor version upon request / version pour moteur fournissable sur demande

SERIE BS88

BS88 series | Série BS88



FUSIBILI BS88 INDUSTRIALI BAO

BAO Industrials BS88 Fuses | Fusibles Industriels BS88 BAO

Caratteristica	Characteristic	Caractéristique
Rapidi	Fast	Rapides
Corrente 40A/63A	Current 40A/63A	Courant 40A/63A
Tensione 550 V	Voltage 550 V	Tension 550 V
Capacità di rottura 80 kA	Breaking capacity 80 kA	Pouvoir de coupure 80 kA
Corpo Ceramica	Body Ceramic	Corps Céramique
Cod. omologazione Bussmann: BAO (A3)	Approval code Bussmann: BAO (A3)	Code d'homologation Bussmann: BAO (A3)
Norme riferimento BS88.1 IEC 60269-1	Standards BS88.1 IEC 60269-1	Normes BS88.1 IEC 60269-1

pag. 158



Codice	Corrente nominale	I ² t	Pot. dissipata
Code	Rated current	I ² t	Power loss
Code	Courant nominal	Ft	Puiss. dissipée
BSBA0040	40 A	5000	4,7
BSBA0050	50 A	11250	4,9
BSBA0063	63 A	25100	5,6

BASE PORTAFUSIBILE

Fuse base | Base porte-fusibles

Codice	Descrizione	Corrente nominale	Tensione
Code	Description	Rated current	Voltage
Code	Description	Courant nominal	Tension
BSCM63F	Base portafusibile/Fuse base/Base porte-fusibles	63 A	660 V

Dimensioni | Dimensions | Dimensions

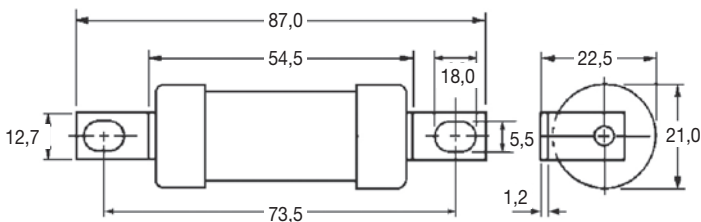

20 pz / 20 pcs / 20 pces
 pronta in stock / en stock
 su richiesta fornibile versione per motore / motor version upon request / version pour moteur fournissable sur demande



FUSIBILI BS88 INDUSTRIALI CEO

CEO Industrials BS88 Fuses | Fusibles Industriels BS88 CEO

Caratteristica	Characteristic	Caractéristique
Rapidi	Fast	Rapides
Corrente 32A/100A	Current 32A/100A	Courant 32A/100A
Tensione 550 V	Voltage 550 V	Tension 550 V
Capacità di rottura 80 kA	Breaking capacity 80 kA	Pouvoir de coupure 80 kA
Corpo Ceramica	Body Ceramic	Corps Céramique
Cod. omologazione Bussmann: CEO (A4)	Approval code Bussmann: CEO (A4)	Code d'homologation Bussmann: CEO (A4)
Norme riferimento BS88.1 IIEC 60269-1	Standards BS88.1 IEC 60269-1	Normes BS88.1 IEC 60269-1

pag. 158



Codice	Corrente nominale	I ² t	Pot. dissipata
Code	Rated current	I ² t	Power loss
Code	Courant nominal	Ft	Puiss. dissipée
BSCE0032	32 A	3700	3,5
BSCE0040	40 A	5000	4,7
BSCE0050	50 A	11500	4,9
BSCE0063	63 A	25700	5,6
BSCE0080	80 A	50000	7,2
BSCE0100	100 A	95600	8,5

SUPPORTI A BLOCCHI

Modular Fuseblocks | Supports à blocs

Codice	Descrizione	Corrente nominale	Tensione
Code	Description	Rated current	Voltage
Code	Description	Courant nominal	Tension
• ULBH0111	Supporti a blocchi/Modular Fuseblocks/Supports à blocs	100 A	700 V

Dimensioni | Dimensions | Dimensions

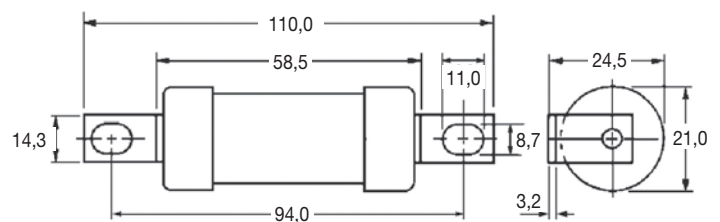

10 pz / 10 pcs / 10 pces
 pronta in stock / en stock
 su richiesta fornibile versione per motore / motor version upon request / version pour moteur fournissable sur demande



• Supporti omologati
Modular fuseblocks approved
Supports à blocs homologues



CARATTERISTICHE DI FUSIONE

Time current characteristics | *Caractéristiques de fusion*

FUSIBILI BS88 LCT e LET BS88 LCT and LET fuses | *Fusibles BS88 LCT et LET*

Caratteristica tempo corrente | Time current characteristics | *Caractéristique temps courant*

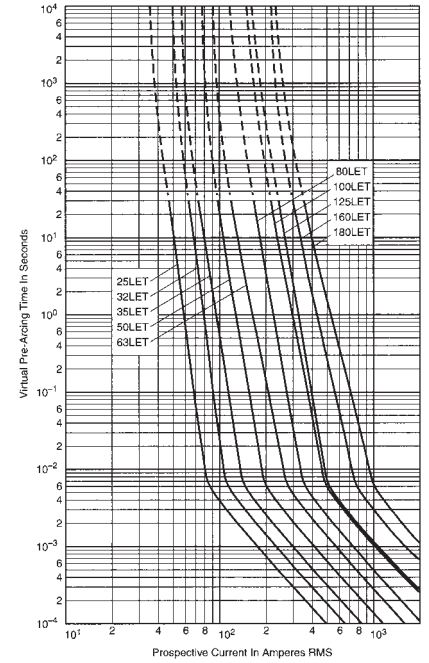
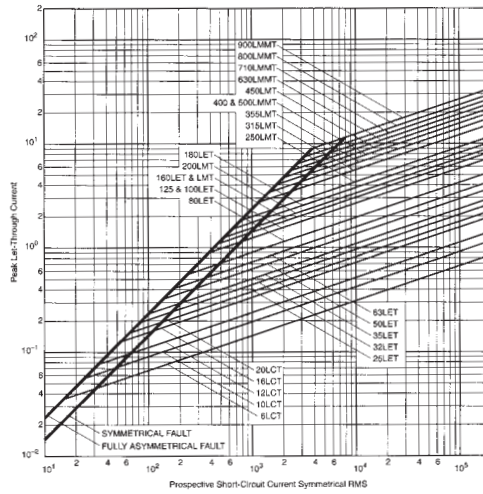
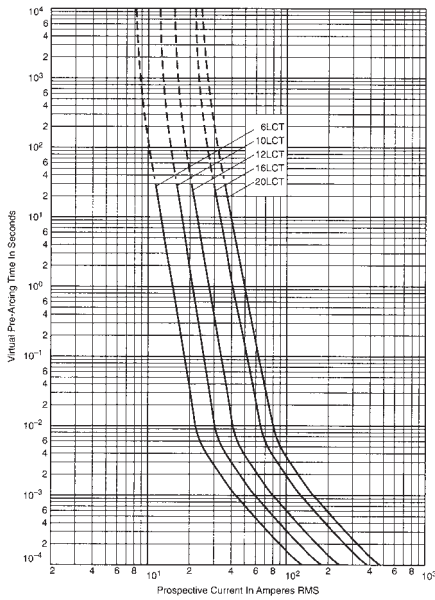

FUSIBILI BS88 LMT e LMMT BS88 LMT and LMMT fuses | *Fusibles BS88 LMT et LMMT*

Caratteristica tempo corrente | Time current characteristics | *Caractéristique temps courant*

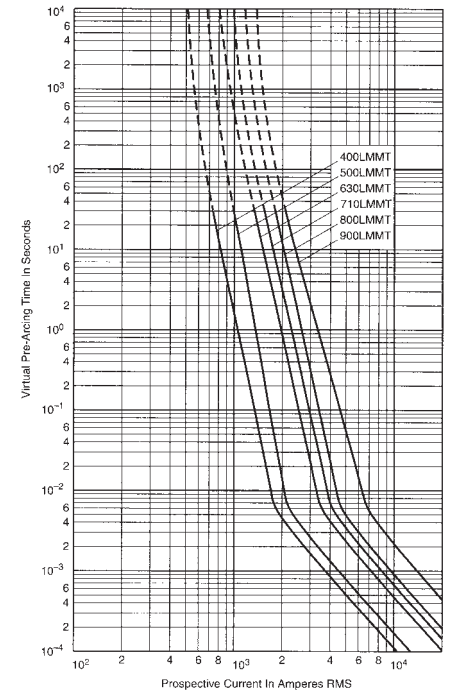
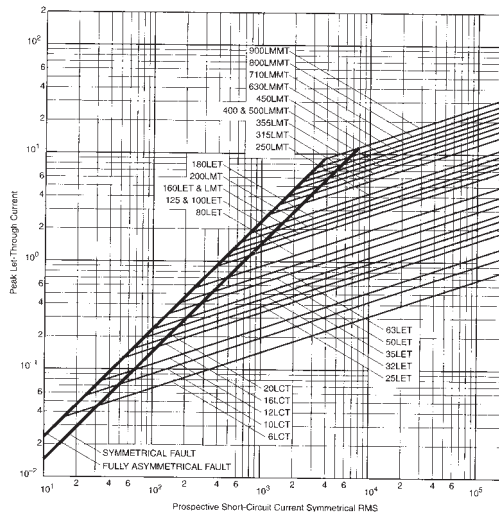
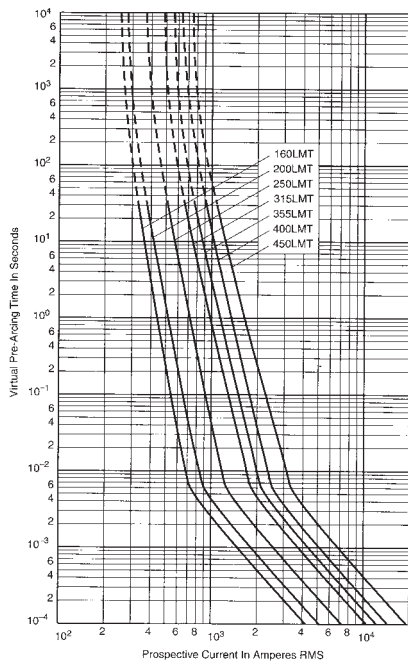

CARATTERISTICHE DI FUSIONE

Time current characteristics | *Caractéristiques de fusion*

FUSIBILI BS88 CT e ET BS88 CT and ET fuses | *Fusibles BS88 CT et ET*

Caratteristica tempo corrente | Time current characteristics | *Caractéristique temps courant*

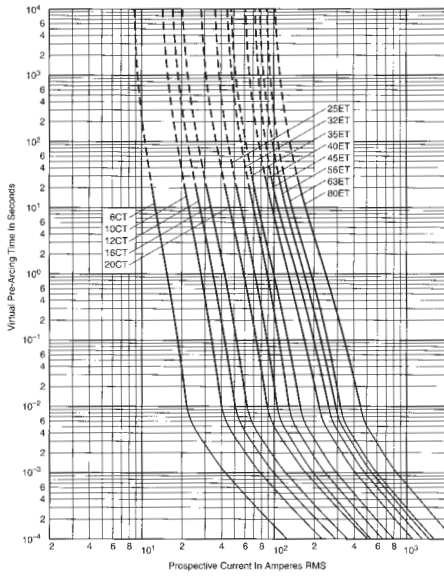

Caratteristiche di limitazione | Peak let-through curve | *Caractéristiques de limitation*

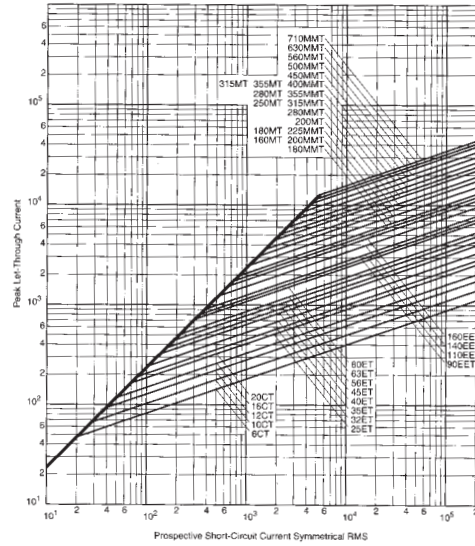

FUSIBILI BS88 EET e MT BS88 EET and MT fuses | *Fusibles BS88 EET et MT*

Caratteristica tempo corrente | Time current characteristics | *Caractéristique temps courant*

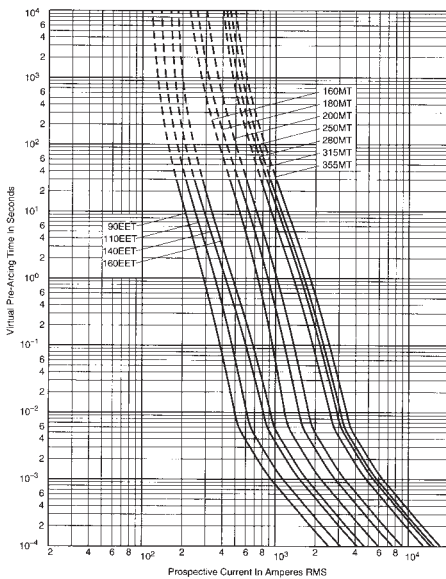

Caratteristiche di limitazione | Peak let-through curve | *Caractéristiques de limitation*

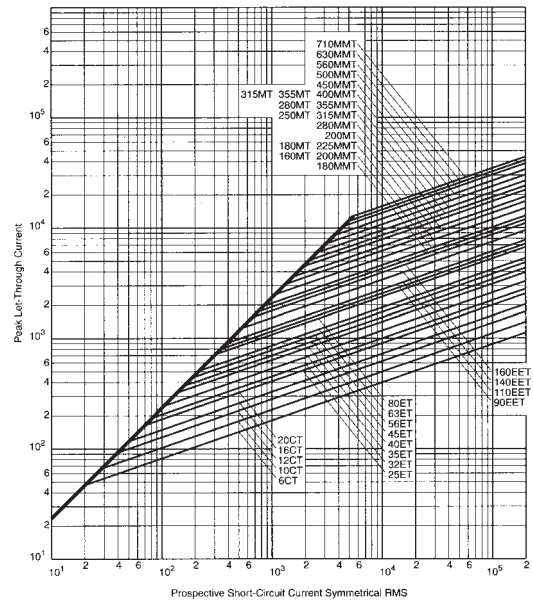

CARATTERISTICHE DI FUSIONE

Time current characteristics | *Caractéristiques de fusion*

FUSIBILI BS88 FE e FM BS88 FE and FM fuses | *Fusibles BS88 FE et FM*

Caratteristica tempo corrente | Time current characteristics | *Caractéristique temps courant*

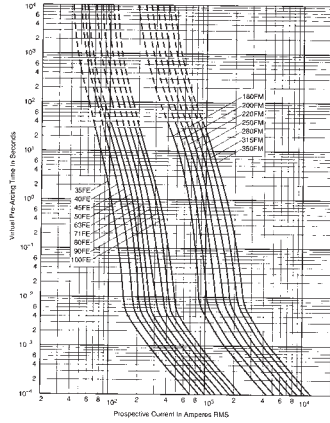

Caratteristiche di limitazione | Peak let-through curve | *Caractéristiques de limitation*

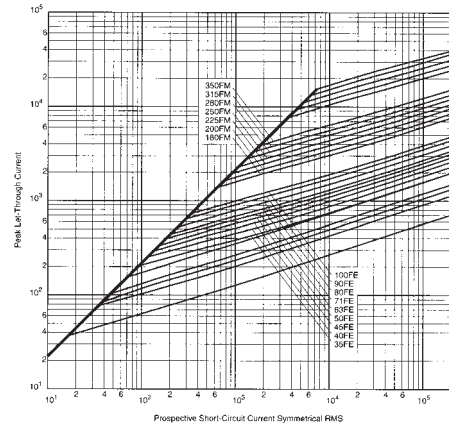

FUSIBILI BS88 FEE e FMM BS88 FEE and FMM fuses | *Fusibles BS88 FEE et FMM*

Caratteristica tempo corrente | Time current characteristics | *Caractéristique temps courant*

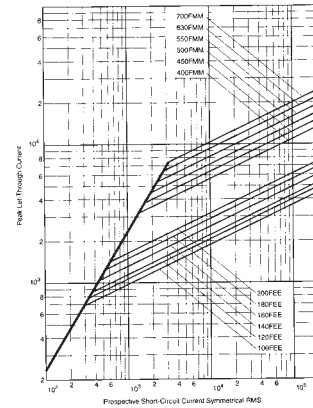
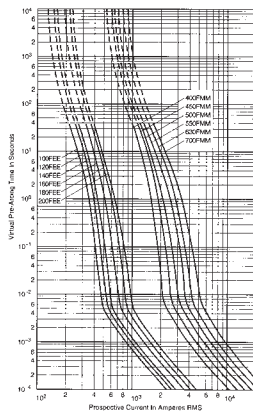

FUSIBILI BS88 MMT BS88 MMT fuses | *Fusibles BS88 MMT*

Caratteristica tempo corrente | Time current characteristics | *Caractéristique temps courant*

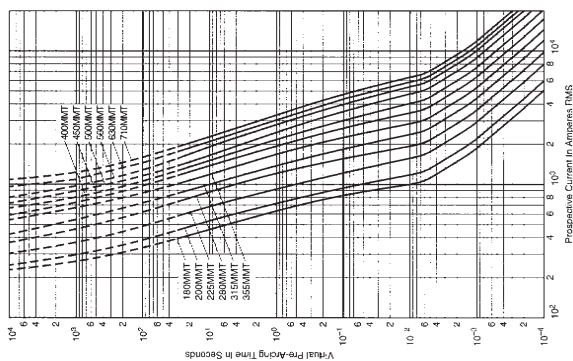

Caratteristiche di limitazione | Peak let-through curve | *Caractéristiques de limitation*

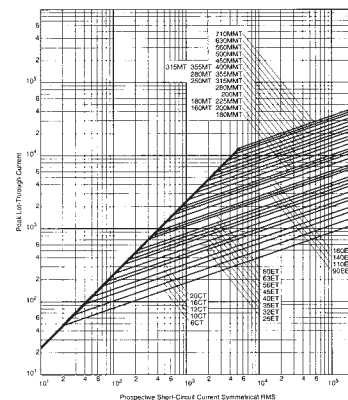

CARATTERISTICHE DI FUSIONE

Time current characteristics | *Caractéristiques de fusion*

FUSIBILI BS88 INDUSTRIALI NITD

NITD Industrials BS88 Fuses | *Fusibles Industriels BS88 NITD*

Caratteristica tempo corrente | Time current characteristics | *Caractéristique temps courant*

Time-Current Characteristic Curve

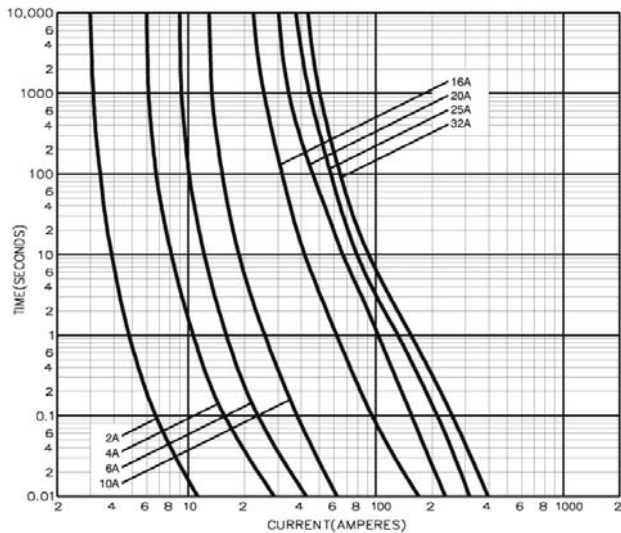

FUSIBILI BS88 INDUSTRIALI AAO

AAO Industrials BS88 Fuses | *Fusibles Industriels BS88 AAO*

Caratteristiche di limitazione | Peak let-through curve | *Caractéristiques de limitation*

Time-Current Characteristic Curves

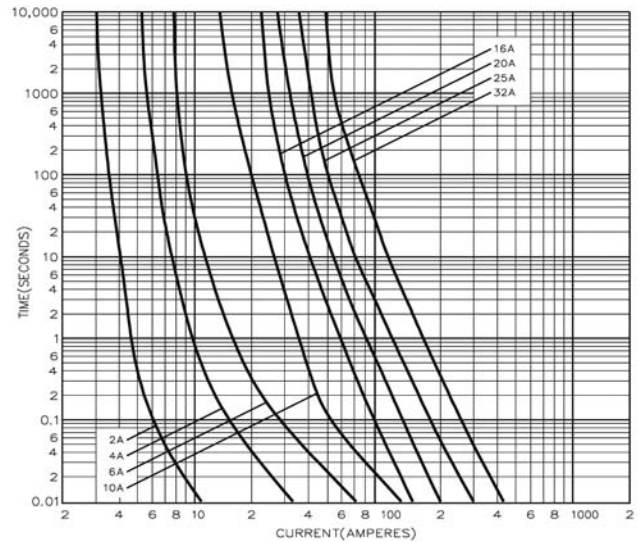

FUSIBILI BS88 INDUSTRIALI BAO

BAO Industrials BS88 Fuses | *Fusibles Industriels BS88 BAO*

Caratteristica tempo corrente | Time current characteristics | *Caractéristique temps courant*

Time-Current Characteristic Curves

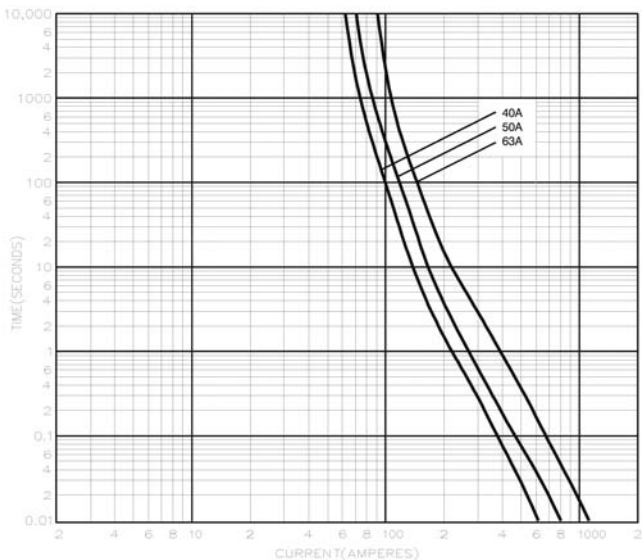

FUSIBILI BS88 INDUSTRIALI CEO

CEO Industrials BS88 Fuses | *Fusibles Industriels BS88 CEO*

Caratteristiche di limitazione | Peak let-through curve | *Caractéristiques de limitation*

Time-Current Characteristic Curves

