



actual size

Oscillator · VCXO · JV53 · 3.3 V

SMD Voltage Control Crystal Oscillator · 5.0 x 3.2 mm

- pulling range up to ± 100 ppm min.
- reflow soldering temperature: 260 °C max.
- ceramic/metal package



General Data

type	JV53 3.3 V	
frequency range	2.0 ~ 54.0 MHz	
frequency stability over all*	± 25 ppm / ± 30 ppm / ± 50 ppm	
	see table 1	
current consumption	see table 2	
supply voltage V_{DC}	3.3 V $\pm 10\%$	
frequency pulling range min.	± 100 ppm (± 150 ppm typ.)	
pulling	control voltage	1.65 V ± 1.35 V*
	linearity	<10%
	input imp. min.	100 K Ω
	modulation min.	20 KHz
temperature	operating	-20 °C ~ +70 °C / -40 °C ~ +85 °C
	storage	-55 °C ~ +125 °C
output	rise & fall time	see table 3
	load max.	15pF
	current max.	4 mA
	low level max.	0.1 x V_{DC}
	high level min.	0.9 x V_{DC}
standby function	no	
start-up time max.	10 ms	
symmetry at 0.5 x V_{DC}	45% ~ 55% max.	

Table 1: Frequency Stability Code

stability code	B	G	C			
	± 50 ppm	± 30 ppm	± 25 ppm			
-20 °C ~ +70 °C	○	○	○			
-40 °C ~ +85 °C	○	○				

● standard ○ available

* includes stability at 25 °C, operating temp. range, supply voltage change, shock and vibration, aging 1st year.

Table 2: Current Consumption max.

Current at 15pF load:	
2.0 ~ 19.9 MHz	10 mA
20.0 ~ 29.9 MHz	15 mA
30.0 ~ 39.9 MHz	20 mA
40.0 ~ 54.0 MHz	25 mA

Table 3: Rise & Fall Time max.

6.0 ns: > 10.0 MHz	note: - specific data on request - rise time: 0.1 V_{DC} ~ 0.9 V_{DC} - fall time: 0.9 V_{DC} ~ 0.1 V_{DC}
10.0 ns: < 10.0 MHz	

Recommendation

To avoid phase noise or FM modulation in the output frequency spectrum, we recommend to feed the Vcontrol input pin by a low source impedance.

For supply voltage noise reduction, connect a capacitor close to the oscillator's supply voltage pins.

Dimensions

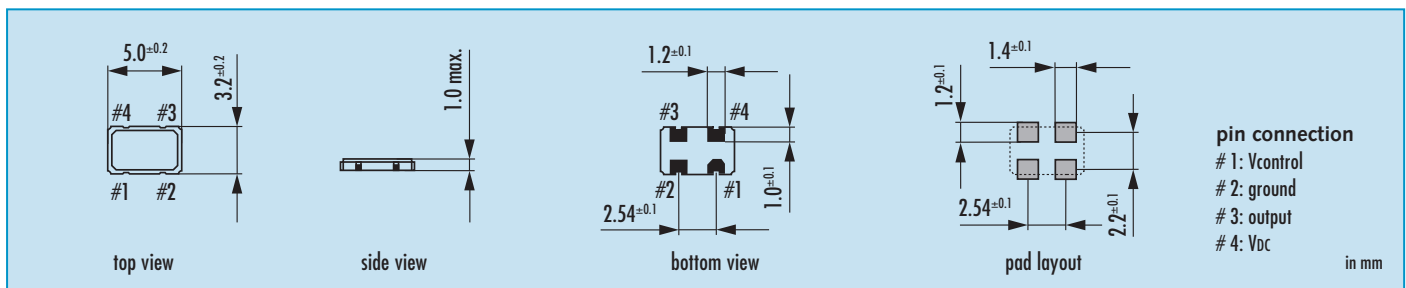

Order Information

0	frequency in MHz	type	frequency stability in ppm	supply voltage in Volt	pulling range in ppm	option
Oscillator	2.0 ~ 54.0 MHz	JV53	C = ± 25 ppm G = ± 30 ppm B = ± 50 ppm	3.3 = 3.3 V	10 = ± 100 ppm	blank = -20 °C ~ +70 °C T1 = -40 °C ~ +85 °C on request

Example: O 27.0-JV53-B-3.3-10-LF (Suffix LF = RoHS compliant / Pb free pins or pads)



Oscillator · VCXO · JV53 · 3.3 V

Taping Specification

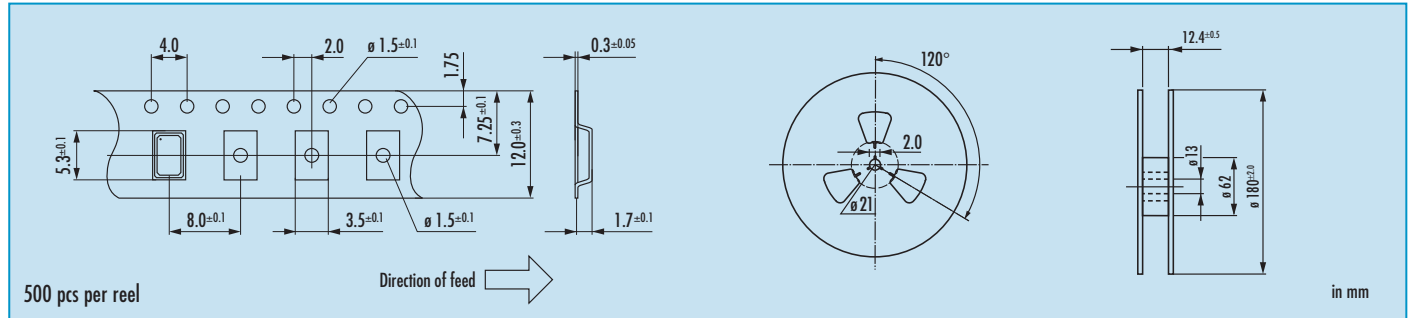

Reflow Soldering Profile

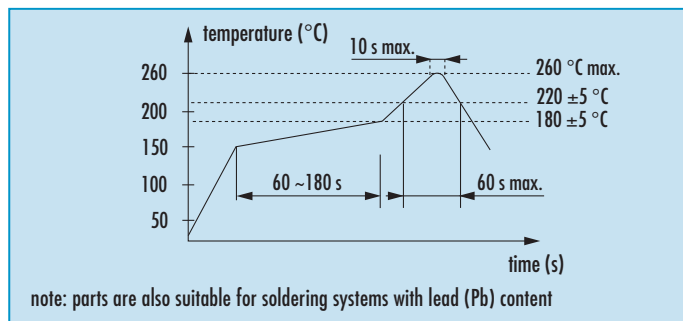

Marking

frequency

type / date code

date code:

A ~ M: Jan. - Dec.
 0: 2010 3: 2013
 1: 2011 4: 2014
 2: 2012 5: 2015

Jan.	Febr.	Mar.	Apr.	May	June
A	B	C	D	E	F
July	Aug.	Sept.	Oct.	Nov.	Dec.
G	H	J	K	L	M

Control Voltage Characteristic

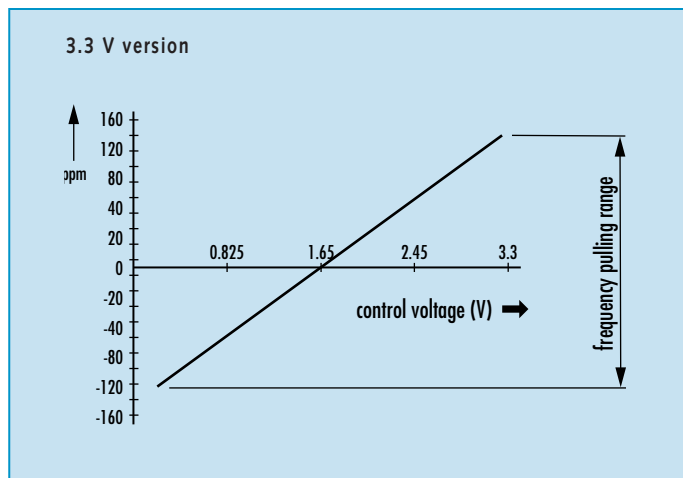

Packing Note

- standard packing units are 500 pieces per reel
- non-multiple packing units are only supplied taped / bulk



actual size

Oscillator · VCXO · 3.3 V

SMD Voltage Control Crystal Oscillator · 7.5 x 5.0 mm

- two pinout versions available
- reflow soldering temperature: 260 °C max.
- ceramic/metal package



General Data

type	JV75 3.3 V	
frequency range	1.0 ~ 125.0 MHz	
frequency stability over all*	± 25ppm* / ± 50ppm	
	see table 1	
current consumption	see table 2	
supply voltage V _{DC}	3.3 V ± 10%	
frequency pulling range min.	± 50ppm / ± 100ppm [▲] / ± 150ppm [♯]	
pulling control voltage	1.65 V ± 1.65 V [♯]	
pulling linearity max.	± 10%	
temperature	operating	-10 °C ~ +70 °C / -40 °C ~ +85 °C
	storage	-40 °C ~ +85 °C
output	rise & fall time	see table 3
	load max.	15pF
	current max.	4mA
	low level max.	0.1 x V _{DC}
	high level min.	0.9 x V _{DC}
standby function	yes	
start-up time max.	10ms	
symmetry at 0.5 x V _{DC}	45% ~ 55% typ. (40% ~ 60% max.)	

Table 1: Frequency Stability Code

stability code	B	C			
	± 50 ppm	± 25 ppm			
-10 °C ~ +70 °C	○	○			
-40 °C ~ +85 °C	○	○			

● standard ○ available

*includes stability at 25 °C, operating temp. range, supply voltage change, shock and vibration, aging 1st year.

Table 2: Current Consumption max.

Current at 15pF load:	
1.0 ~ 29.9 MHz	15 mA
30.0 ~ 44.9 MHz	20 mA
45.0 ~ 51.9 MHz	25 mA
52.0 ~ 125.0 MHz	35 mA

Table 3: Rise & Fall Time max.

6.0 ns:	1.0 ~ 39.9 MHz	note: - specific data on request - rise time: 0.1 V _{DC} ~ 0.9 V _{DC} - fall time: 0.9 V _{DC} ~ 0.1 V _{DC}
5.0 ns:	40.0 ~ 125.0 MHz	

Recommendation

To avoid phase noise or FM modulation in the output frequency spectrum, we recommend to feed the Vcontrol input pin by a low source impedance.

*not available > 52.0 MHz ▲not available > 80.0 MHz ♯on request, if < 52.0 MHz

Dimensions

top view

side view

bottom view

pad layout

standard pin connection B # 1: Vcontrol # 2: e/d # 3: ground # 4: output # 5: nc # 6: VDD	optional pin connection A # 1: Vcontrol # 2: nc # 3: ground # 4: output # 5: e/d # 6: VDD
--	--

in mm

Order Information

0	frequency in MHz	type	frequency stability in ppm	supply voltage in Volt	pulling range in ppm	pin version	option
Oscillator	1.0 ~ 125.0 MHz	JV75	C = ± 25 ppm* B = ± 50 ppm	3.3 = 3.3 V	05 = ±50 ppm 10 = ±100 ppm [▲] 15 = ±150 ppm [♯]	B = standard A = optional	blank = -10 °C ~ +70 °C T1 = -40 °C ~ +85 °C

*not available > 52.0 MHz ▲not available > 80.0 MHz
 ♯on request, if < 52.0 MHz

Example: O 20.0-JV75-C-3.3-10-B (LF = RoHS compliant / Pb free pins or pads)



Oscillator · VCXO · JV75 · 3.3 V

Taping Specification

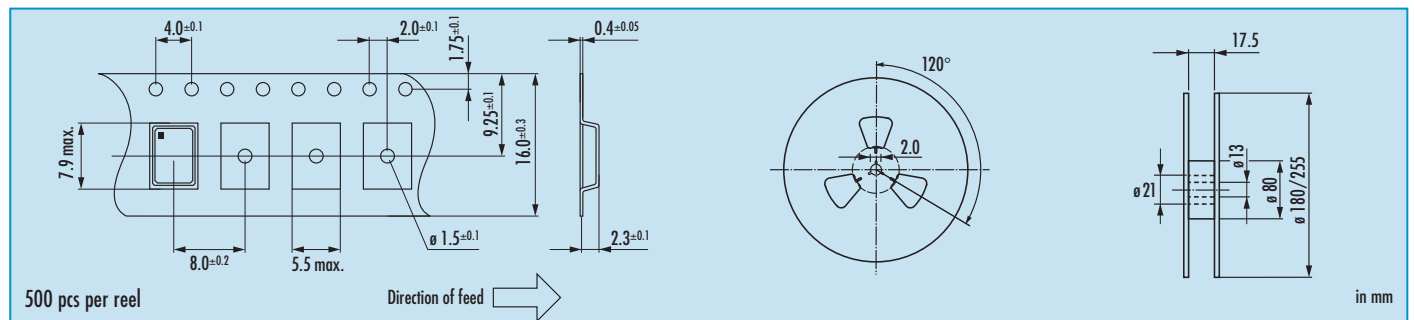

Reflow Soldering Profile

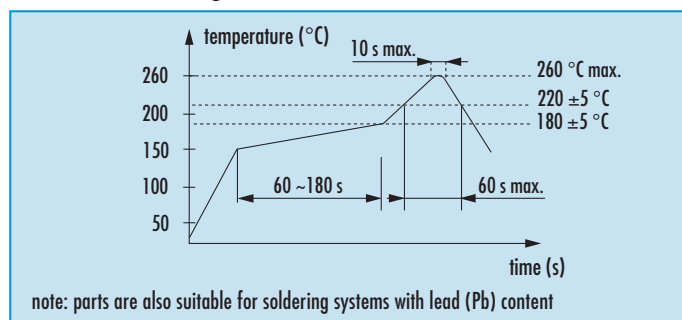

Marking

frequency
type / date code

date code:
A ~ M: Jan. - Dec.
9: 2009
0: 2010
1: 2011

Jan.	Febr.	Mar.	Apr.	May	June
A	B	C	D	E	F
July	Aug.	Sept.	Oct.	Nov.	Dec.
G	H	J	K	L	M

Control Voltage Characteristic

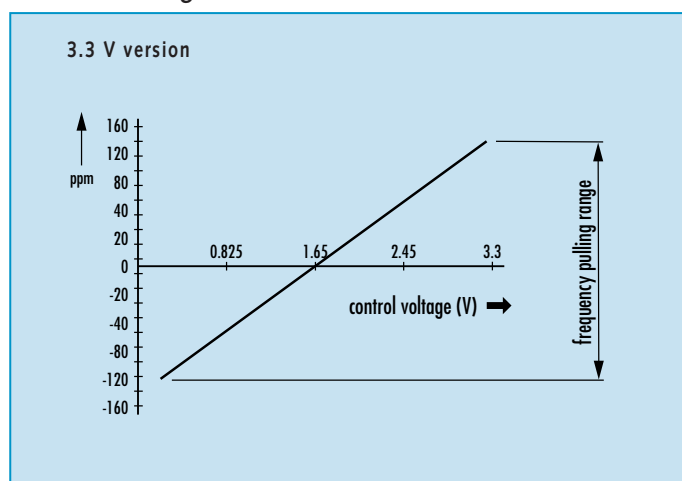

Packing Note

- standard packing units are 500 pieces per reel
- non-multiple packing units are only supplied taped / bulk

Enable / Disable Function

pin #2/#5	pin #4
open or $\geq 0.7 V_{DC}$	enable
gnd or $\geq 0.3 V_{DC}$	high impedance



actual size

Oscillator · VCXO · 5.0 V

SMD Voltage Control Crystal Oscillator · 7.5 x 5.0 mm

- two pinout versions available
- reflow soldering temperature: 260 °C max.
- ceramic/metal package



General Data

type	JV75 5.0 V	
frequency range	1.0 ~ 80.0 MHz	
frequency stability over all*	± 25ppm* / ± 50ppm	
	see table 1	
current consumption	see table 2	
supply voltage V _{DC}	5.0 V ± 5%	
frequency pulling range min.	± 50ppm / ± 100ppm / ± 150ppm [▲]	
pulling control voltage	2.5 V ± 2.0 V [■]	
pulling linearity	<10%	
temperature	operating	-10 °C ~ +70 °C / -40 °C ~ +85 °C
	storage	-55 °C ~ +125 °C
output	rise & fall time	see table 3
	load max.	15pF
	current max.	8mA
	low level max.	0.1 x V _{DC}
	high level min.	0.9 x V _{DC}
standby function	yes	
start-up time max.	10ms	
symmetry at 0.5 x V _{DC}	45% ~ 55% max.	

Table 1: Frequency Stability Code

stability code	B	C			
	± 50 ppm	± 25 ppm			
-10 °C ~ +70 °C	○	○			
-40 °C ~ +85 °C	○	○			

● standard ○ available

* includes stability at 25 °C, operating temp. range, supply voltage change, shock and vibration, aging 1st year.

Table 2: Current Consumption max.

Current at 15pF load:	
1.0 ~ 17.9 MHz	20 mA
18.0 ~ 35.9 MHz	30 mA
36.0 ~ 51.9 MHz	40 mA
52.0 ~ 80.0 MHz	50 mA

Table 3: Rise & Fall Time max.

5.0 ns:	1.0 ~ 39.9 MHz	note: - specific data on request - rise time: 0.1 V _{DC} ~ 0.9 V _{DC} - fall time: 0.9 V _{DC} ~ 0.1 V _{DC}
4.0 ns:	40.0 ~ 80.0 MHz	

Recommendation

To avoid phase noise or FM modulation in the output frequency spectrum, we recommend to feed the Vcontrol input pin by a low source impedance.

* not available > 52.0 MHz ▲ on request, if < 52.0 MHz

Dimensions

top view

side view

bottom view

pad layout

standard pin connection B

1: Vcontrol
2: e/d
3: ground
4: output
5: nc
6: VDD

optional pin connection A

1: Vcontrol
2: nc
3: ground
4: output
5: e/d
6: VDD

in mm

Order Information

0	frequency in MHz	type	frequency stability in ppm	supply voltage in Volt	pulling range in ppm	pin version	option
Oscillator	1.0 ~ 80.0 MHz	JV75	C = ± 25 ppm B = ± 50 ppm	5.0 = 5.0 V	05 = ±50 ppm 10 = ±100 ppm 15 = ±150 ppm*	B = standard A = optional	blank = -10°C ~ +70°C T1 = -40°C ~ +85°C

* on request, if < 52.0 MHz

Example: O 20.0-JV75-B-5.0-10-B (LF = RoHS compliant / Pb free pins or pads)



Oscillator · VCXO · JV75 · 5.0 V

Taping Specification

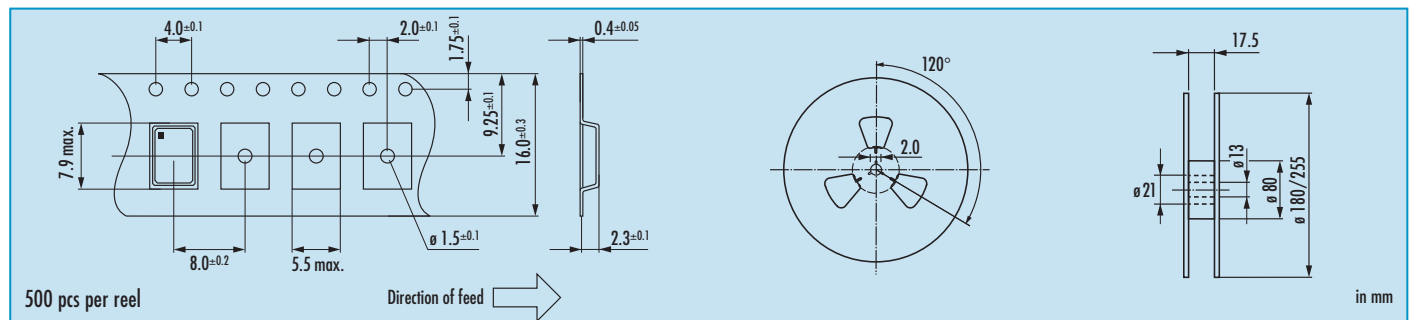

Reflow Soldering Profile

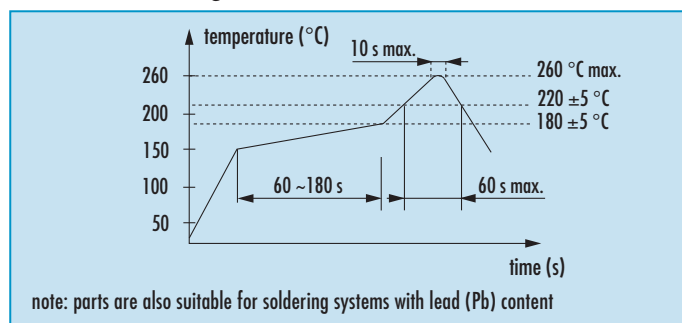

Marking

frequency

type / date code

date code:

A ~ M: Jan. - Dec.

9: 2009

0: 2010

1: 2011

Jan.	Febr.	Mar.	Apr.	May	June
A	B	C	D	E	F
July	Aug.	Sept.	Oct.	Nov.	Dec.
G	H	J	K	L	M

Control Voltage Characteristic

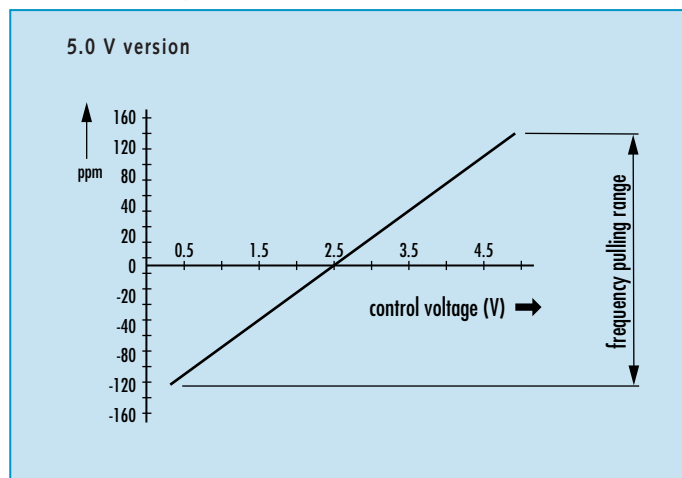

Packing Note

- standard packing units are 500 pieces per reel
- non-multiple packing units are only supplied taped / bulk

Enable / Disable Function

pin #2/#5	pin #4
open or high	oscillation
gnd or low	high impedance