

REV.	DESCRIPTION	DRAWN	CHECKED	APPROVED
A	NEW RELEASE	HP 18/07/05		

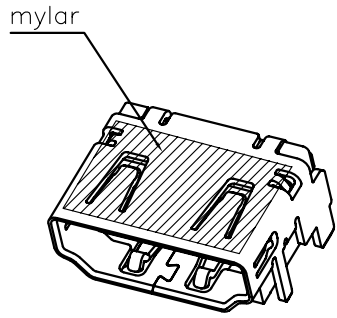

NOTES:

- MATERIALS
  - Insulator: thermoplastic,UL 94V-0 Rated
  - Contacts: Copper Alloy
  - Shell: Copper Alloy
- SPECIFICATION
  - Contact resistance: 50mΩ max.
  - Insulation resistance: 100MΩ min.
  - Dielectric withstanding voltage: 100 VAC 1 minute.
  - Temperature range: -40°C to +80°C.

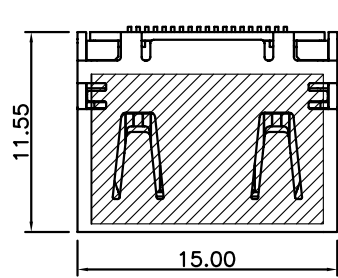
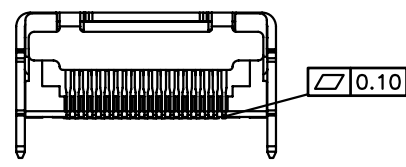
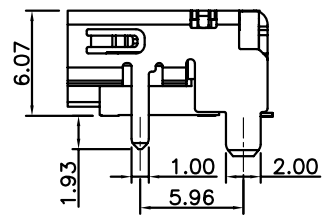
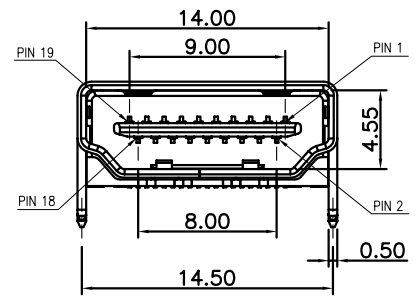

3. PRODUCT NUMBER CODE:

DS1114 - X X X X X

- Packing type
  - R:Tape on reel
  - B:Tube
- MYLAR SUPPORT
  - S:W/ mylar
  - X:W/O mylar
- Contact plating
  - 0: selective gold flash
  - C: selective 3u" gold
  - 1: selective 10u" gold
- Shell plating
  - 6: Tin
  - N: Nickel
- Color of housing
  - B: Black

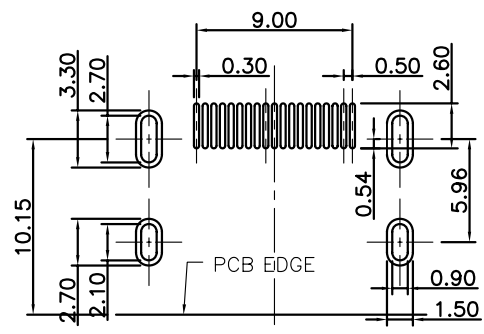

RECOMMEND P.C.B LAYORT  
(Tolerance±0.05)

GENERAL TOLERANCE		ANGLE TOLERANCE		PROJECTION		TITLE
X.	±0.60	X.	±5°	UNITS	mm	HDMI 19PIN Female SMT WITHOUT FLANGE
.X	±0.38	.X	±3°	SHEET SIZE	A4	SERIES DS1114
.XX	±0.25	.XX	±2°			
DRAWING TYPE		CUSTOMER		晨翔电子有限公司 <b>CONNFLY CONNFLY ELECTRONIC CO. LTD</b>		
SCALE		SHEET				
DRAWING NO.		1 OF 1				
		C-DS1114-XXXXX				

REV.	DESCRIPTION	DRAWN	CHECKED	APPROVED
A	NEW RELEASE	HP 18/07/05		

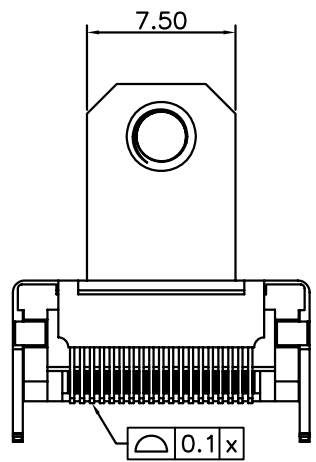
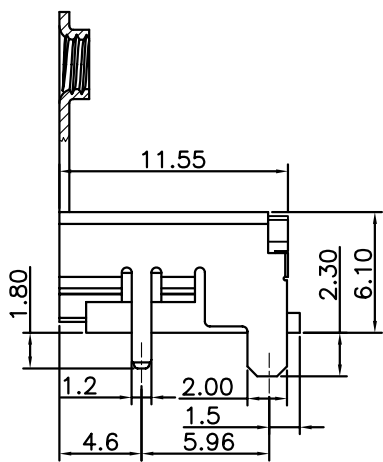
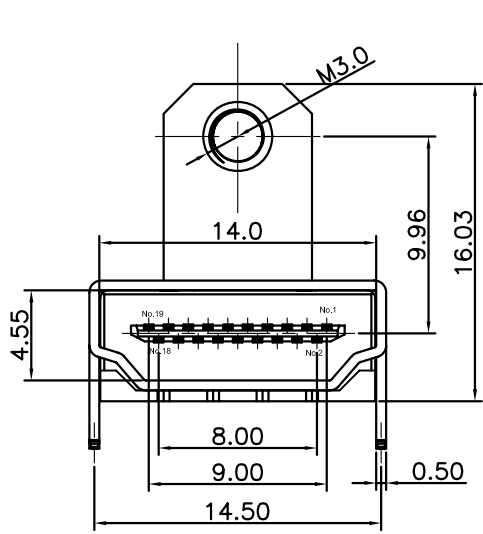

NOTES:

- MATERIALS
  - Insulator: thermoplastic, UL 94V-0 Rated
  - Contacts: Copper Alloy
  - Shell: Copper Alloy
- SPECIFICATION
  - Contact resistance: 50mΩ max.
  - Insulation resistance: 100MΩ min.
  - Dielectric withstanding voltage: 100 VAC 1 minute.
  - Temperature range: -40°C to +80°C.

3. PRODUCT NUMBER CODE:

DS1115 - X X X

- Contact plating
  - 0: selective gold flash
  - C: selective 3u" gold
  - 1: selective 10u" gold
- Shell plating
  - 6: Tin
  - N: Nickel
- Color of housing
  - B: Black

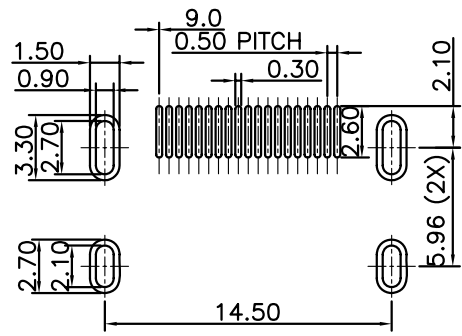
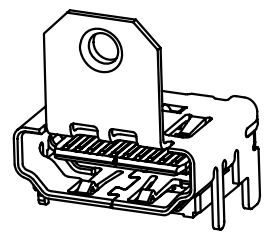
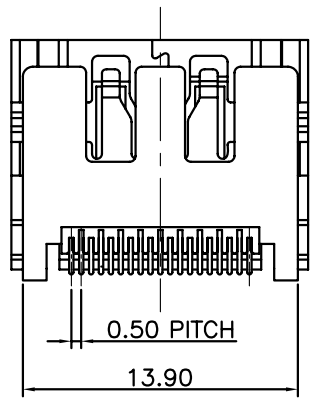

RECOMMEND P.C.B LAYOUT  
(Tolerance±0.05)

GENERAL TOLERANCE		ANGLE TOLERANCE		PROJECTION		TITLE	HDMI Female 19PIN SMT WITH FLANGE
X.	±0.60	X.	±5°	UNITS	mm	SHEET SIZE	A4
.X	±0.38	.X	±3°	SHEET SIZE	A4	SERIES	DS1115
.XX	±0.25	.XX	±2°				
DRAWING TYPE		CUSTOMER		晨翔电子有限公司 <b>CONNFLY CONNFLY ELECTRONIC CO. LTD</b>			
SCALE		SHEET					
DRAWING NO.		C-DS1115-XXX					

REV.	DESCRIPTION	DRAWN	CHECKED	APPROVED
A	NEW RELEASE	LL 11/15/06'		

NOTES:

1. MATERIALS

- . Insulator: thermoplastic, UL 94V-0 Rated
- . Contacts: Copper Alloy
- . Shell: Copper Alloy

2. SPECIFICATION

- . Contact resistance: 50mΩ max.
- . Insulation resistance: 100MΩ min.
- . Dielectric withstanding voltage: 100 VAC 1 minute.
- . Temperature range: -40°C to +105°C.

3. PRODUCT NUMBER CODE:

DS1117 - X X X

- Contact plating
- 0: selective gold flash
- C: selective 3u" gold
- 1: selective 10u" gold
- Shell plating
- 8: Full Gold Flash
- 6: Tin
- N: Nickel
- Color of housing
- B: Black

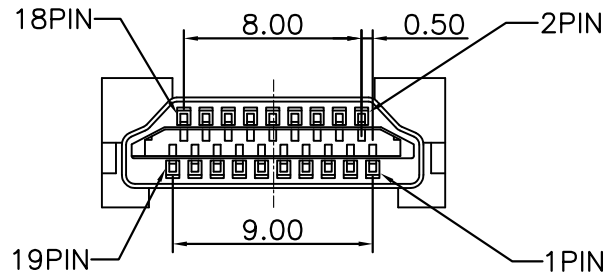
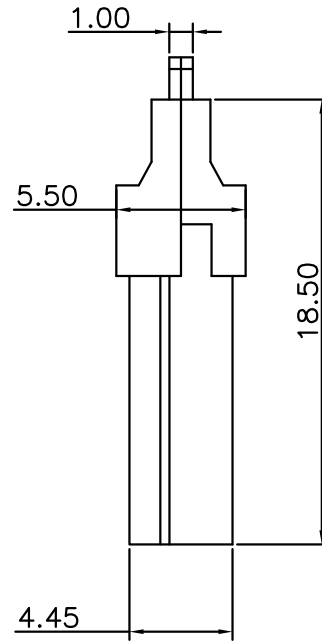
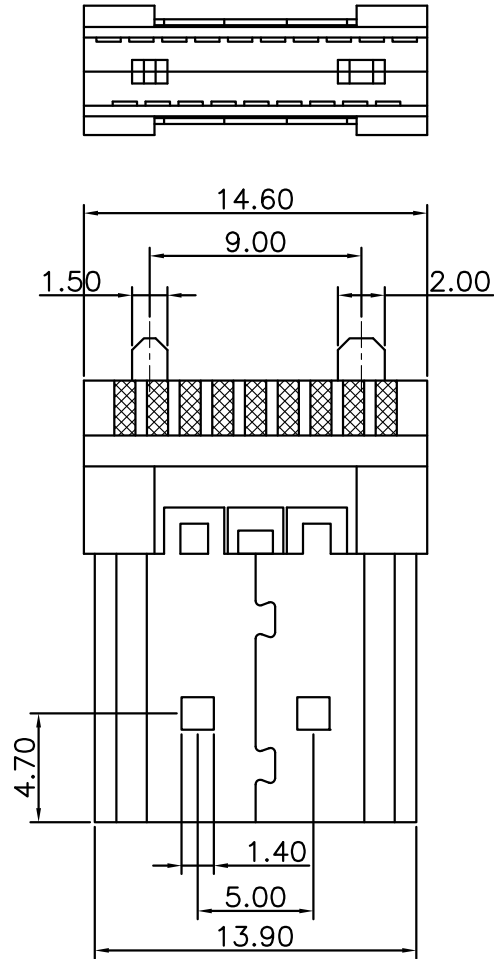

GENERAL TOLERANCE		ANGLE TOLERANCE		PROJECTION		TITLE	HDMI 19PIN MALE Solder type
X.	±0.60	X.	±5°	UNITS	mm	SERIES	DS1117
.X	±0.38	.X	±3°	SHEET SIZE	A4		
.XX	±0.25	.XX	±2°				
DRAWING TYPE	CUSTOMER			晨翔电子有限公司 <b>CONNFLY CONNFLY ELECTRONIC CO. LTD</b>			
SCALE	1:1	SHEET	1 OF 1				
DRAWING NO.	C-DS1117-XXX						

REV.	DESCRIPTION	DRAWN	CHECKED	APPROVED
A	NEW RELEASE	HP 19/07/05		

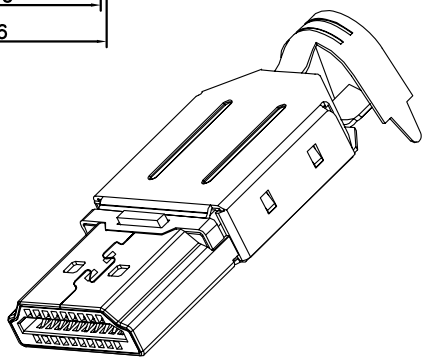
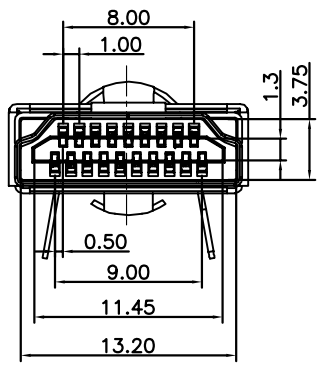
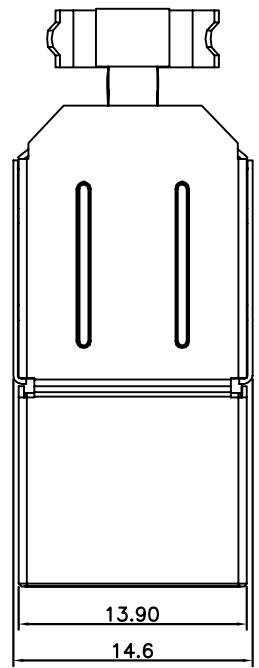
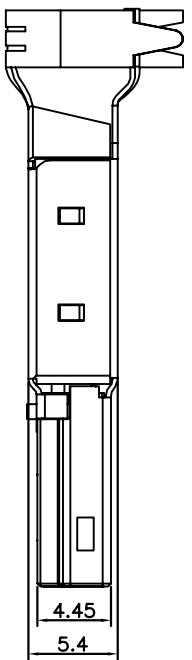
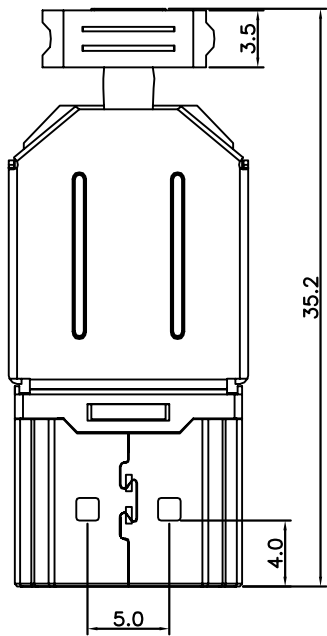

NOTES:

1. MATERIALS

- . Insulator: thermoplastic,UL 94V-0 Rated
- . Contacts: Copper Alloy
- . Shell: Copper Alloy

2. SPECIFICATION

- . Contact resistance: 50mΩ max.
- . Insulation resistance: 100MΩ min.
- . Dielectric withstanding voltage: 100 VAC 1 minute.
- . Temperature range: -40°C to +80°C.

3. PRODUCT NUMBER CODE:

DS1116 - X X X

- Contact plating
  - 0: selective gold flash
  - C: selective 3u" gold
  - 1: selective 10u" gold
- Shell plating
  - 6: Tin
  - N: Nickel
- Color of housing
  - B: Black

GENERAL TOLERANCE		ANGLE TOLERANCE		PROJECTION		TITLE	HDMI 19PIN MALE Solder type WITH BACK SHELL
X.	±0.60	X.	±5°	UNITS	mm		
.X	±0.38	.X	±3°	SHEET SIZE	A4	SERIES	DS1116
.XX	±0.25	.XX	±2°	<b>晨翔电子有限公司</b> <b>CONNFLY CONNFLY ELECTRONIC CO. LTD</b>			
DRAWING TYPE		CUSTOMER					
SCALE	1:1	SHEET	1 OF 1				
DRAWING NO.		C-DS1116-XXX					