

REV.	DESCRIPTION	DRAWN	CHECKED	APPROVED
A	NEW RELEASE	YCH 05/08/12'	~	

N=NUMBER OF CONTACTS

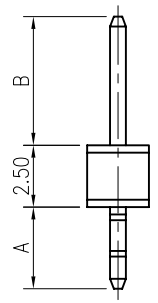
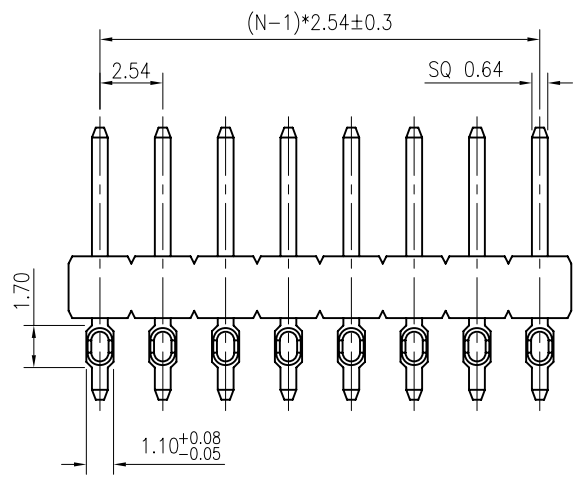
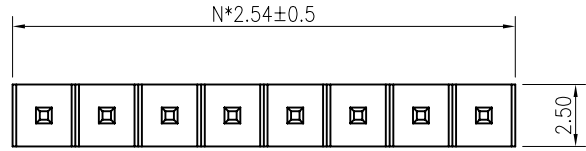

- NOTES:
- ELECTRICAL CHARACTERISTICS:
 - CONTACT RESISTANCE: 20mΩ Max.
 - DIELECTRIC WITHSTANDING VOLTAGE: 500V AC(rms) FOR 1 MINUTE.
 - INSULATION RESISTANCE: 1000MΩ Min.
 - ENVIRONMENT CHARACTERISTICS:
 - OPERATING TEMPERATURE: -40°C~+105°C.
 - PRODUCT NUMBER CODE: DS1021-03- X X X X

TABLE A & DIM. TYPE
 1: TYPE 1 6: TYPE 6
 2: TYPE 2 7: TYPE 7
 3: TYPE 3 8: TYPE 8
 4: TYPE 4 9: TYPE 9
 5: TYPE 5 10: TYPE 10

CONTACT PLATING
 F1: FULL GOLD FLASH
 6: TIN

MOUNTING TYPE
 S: Straight TYPE

No. OF CONTACTS
 1*1~1*40

TABLE A:

TYPE	Dimension	
	A	B
1	3.30	5.20
2	3.30	6.80
3	3.30	8.10
4	3.30	10.20
5	3.30	13.00
6	6.50	5.20
7	6.50	6.80
8	6.50	8.10
9	6.50	10.20
10	6.50	13.00

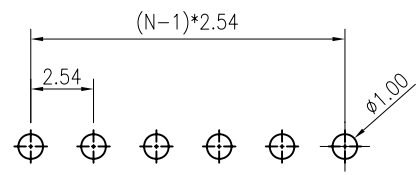

RECOMMEND PCB LAYOUT
 (TOLERANCE=±0.05)

GENERAL TOLERANCE		ANGLE TOLERANCE		PROJECTION		TITLE	PIN HEADER PITCH 2.54mm	
X.	±0.60	X.	±5'	UNITS	mm		PRESS-FIT SINGLE TYPE	
.X	±0.38	.X	±3'	SHEET SIZE	A4	SERIES	DS1021-03 SERIES	
.XX	±0.25	.XX	±2'	晨翔电子有限公司 CONNFLY CONNFLY ELECTRONIC CO. LTD				
DRAWING TYPE		CUSTOMER						
SCALE		SHEET 1 OF 2						
DRAWING NO.		C-DS1021-03-1*XXX						

REV.	DESCRIPTION	DRAWN	CHECKED	APPROVED
A	NEW RELEASE	YCH 05/08/12'	~	

N=NUMBER OF CONTACTS

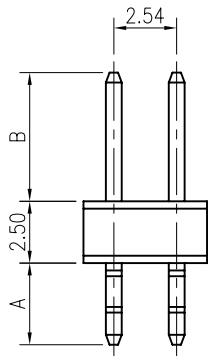
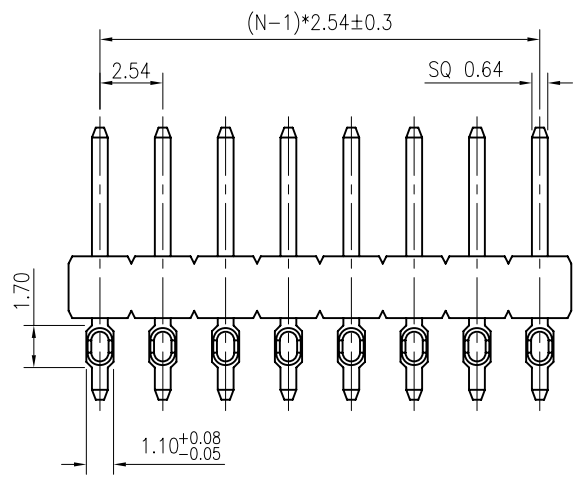
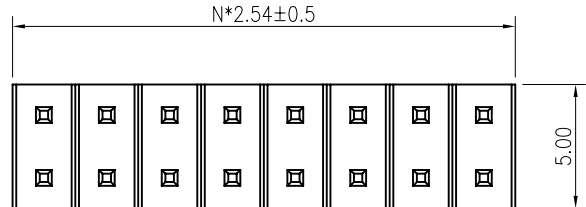

NOTES:

- ELECTRICAL CHARACTERISTICS:
 - CONTACT RESISTANCE: 20mΩ Max.
 - DIELECTRIC WITHSTANDING VOLTAGE: 500V AC(rms) FOR 1 MINUTE.
 - INSULATION RESISTANCE: 1000MΩ Min.
- ENVIRONMENT CHARACTERISTICS:
 - OPERATING TEMPERATURE: -40°C~+105°C.
- PRODUCT NUMBER CODE: DS1021-04- X X X X

TABLE A & DIM. TYPE
 1: TYPE 1 6: TYPE 6
 2: TYPE 2 7: TYPE 7
 3: TYPE 3 8: TYPE 8
 4: TYPE 4 9: TYPE 9
 5: TYPE 5 10: TYPE 10

CONTACT PLATING
 F1: FULL GOLD FLASH
 6: TIN

MOUNTING TYPE
 S: Straight TYPE

No. OF CONTACTS
 2*2~2*40

TABLE A:

TYPE	Dimension	
	A	B
1	3.30	5.20
2	3.30	6.80
3	3.30	8.10
4	3.30	10.20
5	3.30	13.00
6	6.50	5.20
7	6.50	6.80
8	6.50	8.10
9	6.50	10.20
10	6.50	13.00

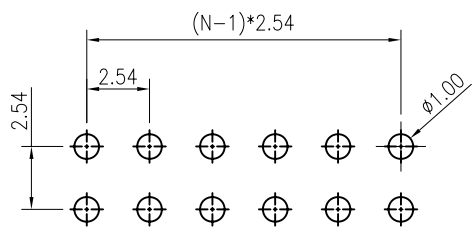

RECOMMEND PCB LAYOUT
 (TOLERANCE=±0.05)

GENERAL TOLERANCE		ANGLE TOLERANCE		PROJECTION		TITLE	PIN HEADER PITCH 2.54mm	
X.	±0.60	X.	±5'	UNITS	mm		PRESS-FIT DOUBLE TYPE	
.X	±0.38	.X	±3'	SHEET SIZE	A4	SERIES	DS1021-04 SERIES	
.XX	±0.25	.XX	±2'			 晨翔电子有限公司 CONNFLY CONNFLY ELECTRONIC CO. LTD		
DRAWING TYPE		CUSTOMER						
SCALE		SHEET		1 OF 2				
DRAWING NO.		C-DS1021-04-2*XXX						

REV.	DESCRIPTION	DRAWN	CHECKED	APPROVED
A	NEW RELEASE	YCH 05/08/12'	~	

N=NUMBER OF CONTACTS

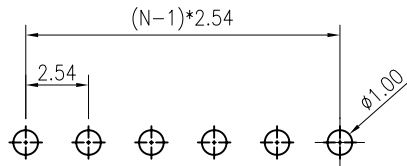
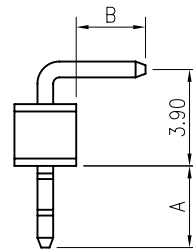
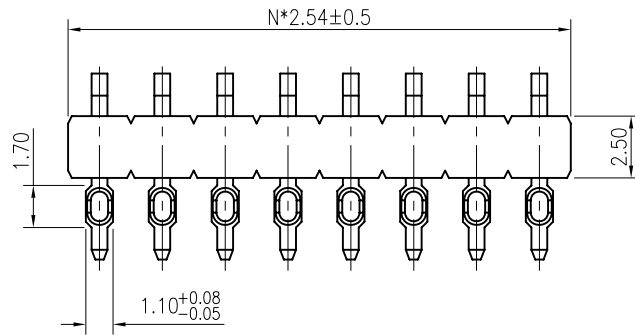
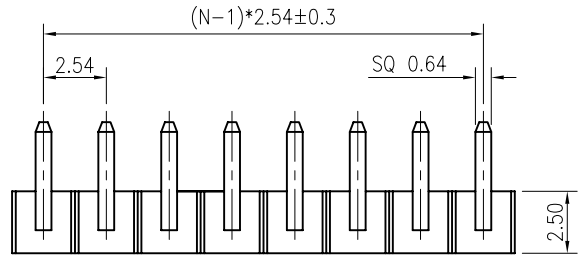

RECOMMEND PCB LAYOUT
(TOLERANCE=±0.05)

NOTES:

- ELECTRICAL CHARACTERISTICS:
 - CONTACT RESISTANCE: 20mΩ Max.
 - DIELECTRIC WITHSTANDING VOLTAGE: 500V AC(rms) FOR 1 MINUTE.
 - INSULATION RESISTANCE: 1000MΩ Min.
- ENVIRONMENT CHARACTERISTICS:
 - OPERATING TEMPERATURE: -40°C~+105°C.
- PRODUCT NUMBER CODE:
DS1022-11- X X X X

TABLE A & DIM. TYPE
1: TYPE 1
2: TYPE 2
...

CONTACT PLATING
F1: FULL GOLD FLASH
6: TIN

MOUNTING TYPE
R: R/A

No. OF CONTACTS
1*1~1*40

TABLE A:

TYPE	Dimension	
	A	B
1	3.30	2.80
2	3.30	5.60
3		
4		
5		
6		
7		
8		
9		
10		

GENERAL TOLERANCE		ANGLE TOLERANCE		PROJECTION		TITLE	PIN HEADER PITCH 2.54mm	
X.	±0.60	X.	±5°	UNITS	mm		PRESS-FIT SINGLE R/A TYPE	
.X	±0.38	.X	±3'	SHEET SIZE	A4	SERIES	DS1022-11 SERIES	
.XX	±0.25	.XX	±2'			晨翔电子有限公司 CONNFLY CONNFLY ELECTRONIC CO. LTD		
DRAWING TYPE		CUSTOMER						
SCALE		SHEET		1 OF 2				
DRAWING NO.		C-DS1022-11-1*XXX						

REV.	DESCRIPTION	DRAWN	CHECKED	APPROVED
A	NEW RELEASE	YCH 05/08/12'	~	

N=NUMBER OF CONTACTS

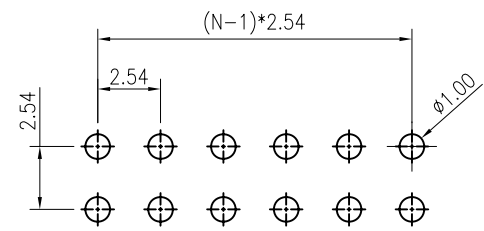
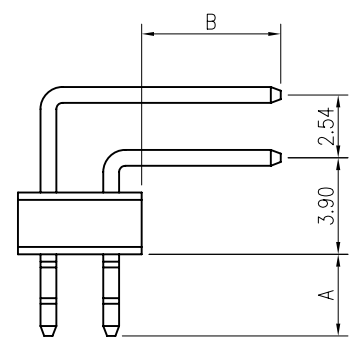
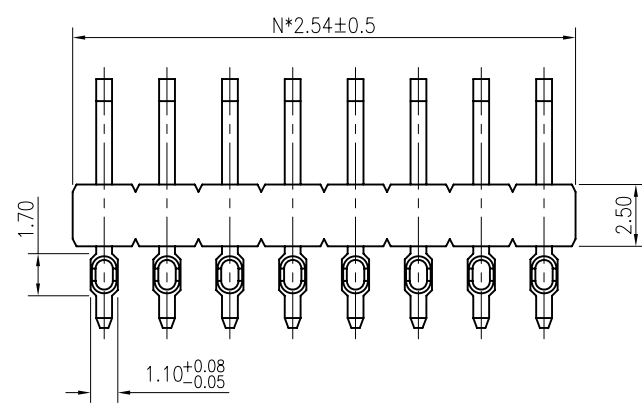
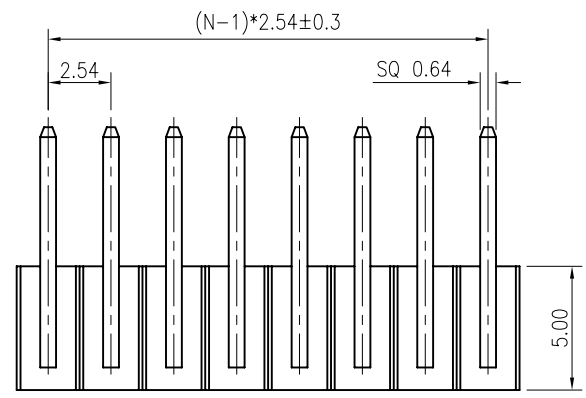

RECOMMEND PCB LAYOUT
(TOLERANCE=±0.05)

NOTES:

- ELECTRICAL CHARACTERISTICS:
 - CONTACT RESISTANCE: 20mΩ Max.
 - DIELECTRIC WITHSTANDING VOLTAGE: 500V AC(rms) FOR 1 MINUTE.
 - INSULATION RESISTANCE: 1000MΩ Min.
- ENVIRONMENT CHARACTERISTICS:
 - OPERATING TEMPERATURE: -40°C~+105°C.
- PRODUCT NUMBER CODE:

DS1022-12- X X X X

TABLE A & DIM. TYPE
1: TYPE 1
2: TYPE 2
:
CONTACT PLATING
F1: FULL GOLD FLASH
6: TIN
MOUNTING TYPE
R: R/A
No. OF CONTACTS
2*2~2*40

TABLE A:

TYPE	Dimension	
	A	B
1	3.30	2.80
2	3.30	5.60
3		
4		
5		
6		
7		
8		
9		
10		

GENERAL TOLERANCE		ANGLE TOLERANCE		PROJECTION		TITLE	PIN HEADER PITCH 2.54mm	
X.	±0.60	X.	±5'	UNITS	mm		PRESS-FIT DOUBLE R/A TYPE	
.X	±0.38	.X	±3'	SHEET SIZE	A4	SERIES	DS1022-12 SERIES	
.XX	±0.25	.XX	±2'			晨翔电子有限公司 CONNFLY CONNFLY ELECTRONIC CO. LTD		
DRAWING TYPE		CUSTOMER						
SCALE		SHEET		1 OF 2				
DRAWING NO.		C-DS1022-12-2*XXX						